

**Panasonic**  
ideas for life

# GTseries

Programmable Display

GT01 GT01R GT05 GT11 GT21C GT32

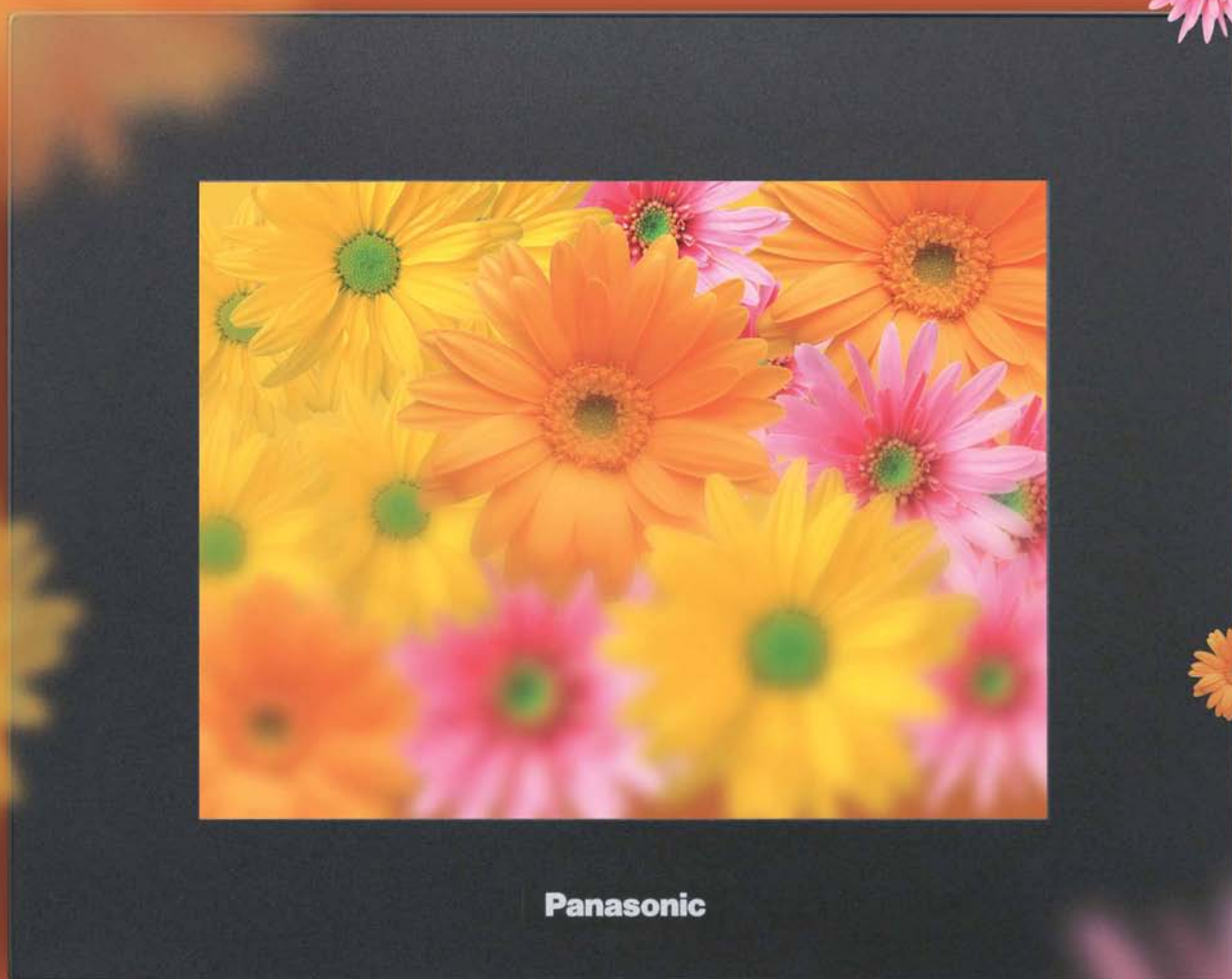

Touch and feel the vividness.

Programmable Display GT series  
ARCT1B305E '08.4

**New**

		GT01	GT01R	GT11	GT05M
					
					
		<b>GT01</b>	<b>GT01R</b>	<b>GT11</b>	<b>GT05M</b>
Rated voltage		5V DC/24V DC	5V DC/24V DC	24V DC	24V DC
Display	Screen size	3 inch	3 inch	4 inch	3.5 inch
	Display device	STN monochrome LCD	STN monochrome LCD	STN monochrome LCD	STN monochrome LCD
	Display color	2 colors (black/white)	2 colors (black/white)	2 colors (black/white)	2 colors (black/white)
	Resolution	128 (W) × 64 (H) dots	128 (W) × 64 (H) dots	240 (W) × 96 (H) dots	320 (W) × 240 (H)
	Backlight	3-color LED (green/orange/red)	3-color LED (white/pink/red)	3-color LED (green/orange/red)/White LED	3-color LED (white/pink/red)
	Displayable characters*	72 characters	72 characters	216 characters	768 characters
Memory capacity (F-ROM)		384 Kbyte	384 Kbyte	1.375 Mbyte	2 Mbyte
External interface	Serial port	RS232C / RS422 (RS485)	RS232C / RS422 (RS485)	RS232C / RS422 (RS485)	RS232C / RS422 (RS485)
	USB port	—	—	—	○
	Ethernet	—	—	—	—
	SD memory card	—	—	—	○
Sound output jack		—	—	—	—
*10-dot font					

# GTseries

## LINE UP

GT32T/GT32M

GT21C

GT11

GT05M/GT05G/GT05S

GT01R

GT01



### GT05G

### GT05S

### GT21C

### GT32M

### GT32T0 GT32T1

24V DC	24V DC	24V DC	24V DC	24V DC	
3.5 inch	3.5 inch	4.7 inch	5.7 inch	5.5 inch	
STN monochrome LCD	STN color LCD	STN color LCD	STN monochrome LCD	TFT color LCD	
2 colors (black/white)	4,096 colors	256 colors	2 colors (blue/white)	4,096 colors	
320 (W) × 240 (H)	320 (W) × 240 (H)	320 (W) × 240 (H) dots	320 (W) × 240 (H) dots	320 (W) × 240 (H) dots	
3-color LED (green/orange/red)	White LED	White LED	CFL	CFL	
768 characters	768 characters	768 characters	768 characters	768 characters	
2 Mbyte	12 Mbyte	6.5 Mbyte	2 Mbyte	12 Mbyte	
RS232C / RS422 (RS485)	RS232C / RS422 (RS485)	RS232C / RS422 (RS485)	RS232C / RS422 (RS485)	RS232C / RS422 (RS485)	
○	○	—	○	○	○
—	—	—	—	—	○
○	○	—	○	○	○
—	—	—	—	—	○

GT series programmable displays pursuing the fundamentals of communication ultimately brings out the beauty of functionality.

Look, listen, and touch.



# What are the very basic concepts of programmable displays?

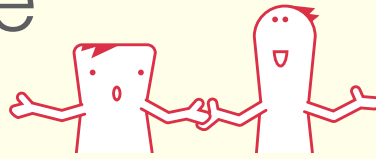

Programmable displays are also called HMI (human-machine interfaces), which communicate human intentions to the machine, communicate the machine's status to humans, and await further instructions.

“More accurate, quicker, and easier operations”

Based on this very basic concept, Matsushita Electric Works GT series programmable displays focuses on operator friendliness and easier communication of information by machines (machine designers).

## GTseries

### Features 1

Enhanced development efficiency for system designers



### Multiple GT displays can be connected to our FP series PLC.

new

(GT05/GT32) (Available soon)

#### • GT link function

Up to 32 GT displays can be connected to one PLC unit without communication programs. The same screen operation is possible at a conveyor line or other remote locations, and the number of PLC units can be reduced, cutting the production process costs.

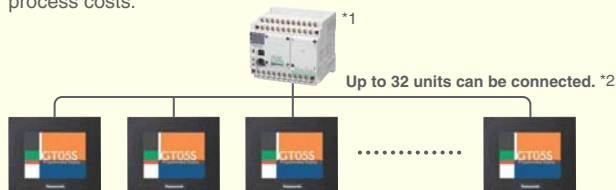

#### [Priority modes]

In display-priority mode, the update of displays, such as lamp indications, messages, and data values, is prioritized. In control-priority mode, switch-on/off operations and data value control are prioritized.

#### [Exclusive connection with PLC]

This function allows communications between the PLC and a specific GT display only. The exclusive communication can be enabled at the proper timing, and the response speed of the GT display can be prioritized, maintaining communication quality as if in one-to-one connection.

\*1: Our FP series PLC

\*2: As the number of connected units increases, the response slows down. Check the speed in the actual line. (Connection of four or less units is recommended.)

### Security enhanced by password-protection (GT05/GT32)

(Available soon)

new

Password-protection and operation security functions protect the data asset in the display unit and control the authorization for operation.

#### • Password-protection function

The screen data upload operation can be restricted by using passwords to protect the data asset in the display unit.

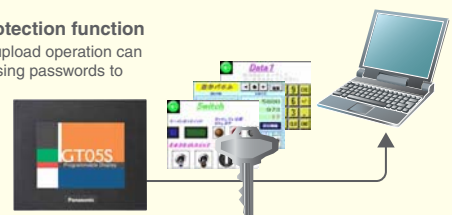

#### • Operation security function

Up to 64 operators can set individual passwords, and up to 16 levels of restrictions can be set on displays and operations for each part. The registered users and passwords can be changed on the display panel.

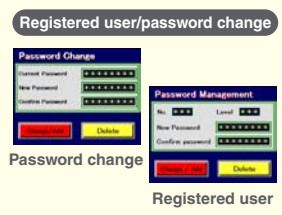
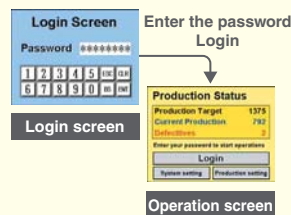

\* Screens under development

## Cost and space saving

Eliminates the need for arranging many parts, securing a stock of parts, and wiring each switch.



- Improves the design and operability
- Easy to change the settings by model and user

## Easy-to-switch language

Conventionally, screens were created for each language. With this new language switching function, data can be registered in multiple languages (up to 16) for each part. The characters can be easily edited with Microsoft Excel and then imported.

	Japanese	English	Simplified Chinese	Traditional Chinese	Korean
000 SW0	日本語	English	简体中文語	繁體中國語	한국어
000 SW0	ありがとうございます	Thank you	热烈欢迎	請多指教	안녕하
000 SW1 1	1	1	1	1	1
000 SW1 2	2	2	2	2	2

## Wide variety of functions

### “Write Device function”



This function modifies the PLC data or turns bits on/off according to the PLC status or the screen No.

### “Recipe function”



Settings by product item and other data (up to 3,600 words) can be transferred to PLC, simplifying PLC programming.

### “Graph function”

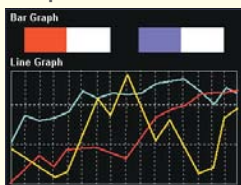

You can identify the production or operation status in line or bar graph form.

### “Flow Display function”



A flowing message of up to 64 characters (two-byte) can be displayed at the bottom of the screen. (128 messages)

## The backlight can be controlled via PLC.

For example, when a sensor detects a person, the display backlight can be turned by an instruction from a PLC. It is also possible to turn off the backlight when a preset period of time elapses after the last operation.

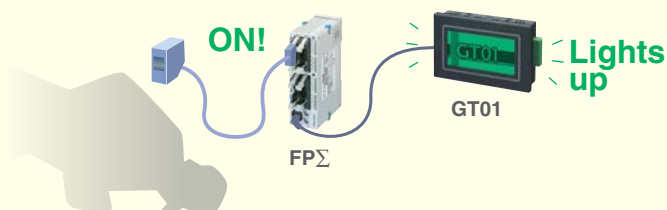

## Custom switches

Capable of creating custom switches using bitmap data, multicolor custom lamps, and display of multiple text messages.



## Compatible with the eight languages for the GTWIN menu

<Available languages>



## RS232C/RS422 (RS485) Interface

Equipped with an RS232C/RS422 (RS485) serial port, which allows connection with a PLC from various companies (Please refer to the PLC Compatibility table.)

\*The RS422 type can be connected at a maximum distance of 500m.

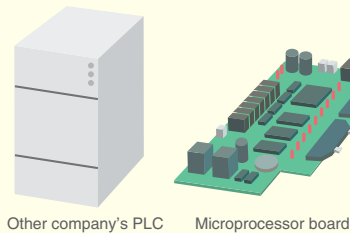

Also supports connection with a PLC of another company or a microprocessor board.

## Startup screen

An original screen can be displayed for a specified period of time after startup.



# GTseries

## Features 2

### Improved visibility and operability for operators



#### Colorful images for higher visibility!

The display size is small, but the image quality is excellent. GT05S and GT32T can display images in 4,096 colors, which can show colorful bitmap images at a high level of quality. For example, pictures of sample products can be easily displayed by copying and pasting them on GTWIN.



#### Speedy operation

The response speed of programmable displays largely depends on the communication speed of the controller, such as PLC, as well as that of the displays themselves. GT series displays support high-speed communications at up to 115.2 kbps, allowing speedy operation.

\*Communications at 115.2 kbps are available only when the PLC supports communications at 115.2 kbps.

#### Three-color LED backlights, which allow for checking the machine status at a glance

The monochrome type (except GT32M) has a three-color LED backlight. It allows operators to check the equipment status at a glance by changing the background color to, for example, green under normal conditions, orange during operation, and red in emergency situations.

GT05G



(Normal)

GT11

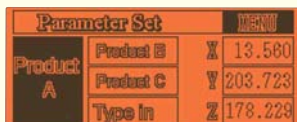

(In operation)

GT01R/GT01



(Emergency)

#### Error warning by voice messages (GT32T1)

Voice messages or melodies immediately communicate the equipment status to operators not located near the equipment. The sound files are compatible with WAV format, which can be easily prepared by a PC.

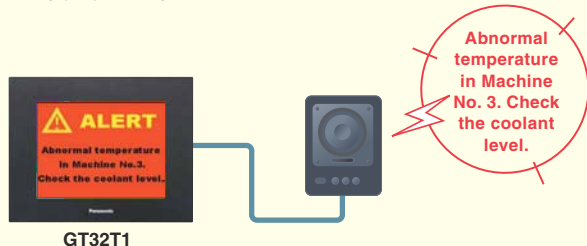

GT32T1

#### Higher flexibility of screen design

GT series displays use an analog-touch panel where locations of parts and characters can be adjusted in increments of one dot. The adoption of the Windows font has widened the character size selection (10 to 240 dots), making the screen design more flexible.

\*The maximum size varies depending on the model.

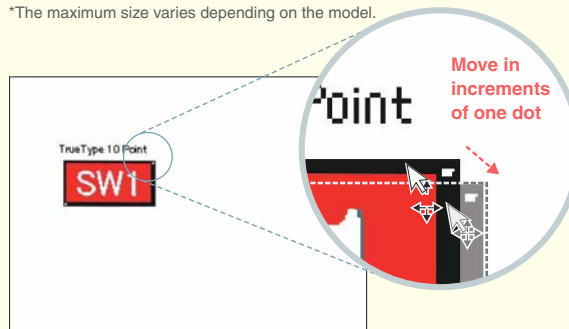

#### “Analog-touch design”

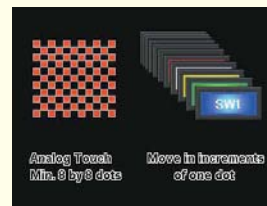
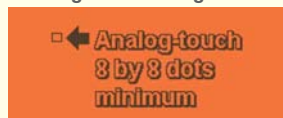

#### “TrueType fonts”



The adoption of the Windows® font has made it possible to choose a font focusing on the screen image and visual quality.



# Features 3

## Simple maintenance

### High-efficiency operation by the “through” function

This function allows operators to simultaneously carry out the transfer of screen data of a GT series display and the debugging of our FP series PLC connected to the display. GT32T1 supports Ethernet connection, which allows the “through” function to be controlled from a remote location.

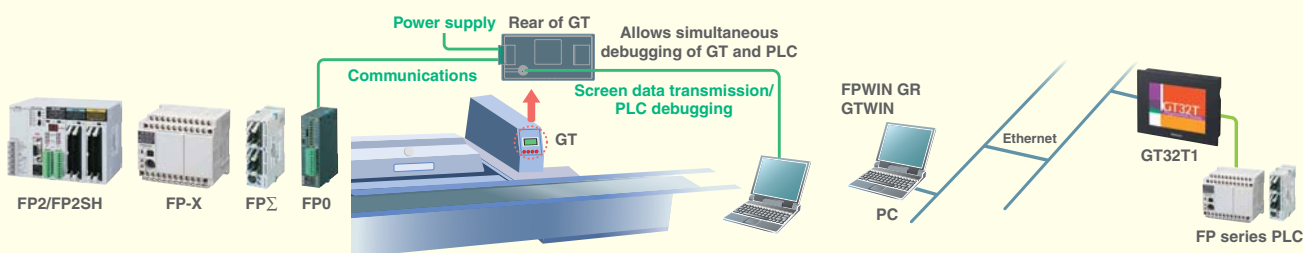

### USB interface equipment

(GT05/GT32)

You can connect your PC and GT using your USB cable to transfer screen data.

\*Also supports the “through” function for our FP series PLC.

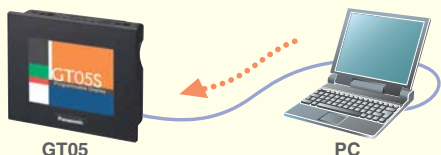

### Slot for SD memory card of up to 1 GB

(GT05/GT32)

Easy to copy screen data. Also serves as storage for output sound files. (GT32T1)



### Maintenance-free LED backlight

(GT01/GT01R/GT05/GT11/GT21C)

The use of the LED backlight eliminated backlight replacement work.

### Alarm list

(GT05/GT11/GT21C/GT32)

Alarm activation, check, and recovery can be recorded and displayed.

Line 1 Alarm History	
04/12/24 23:55:57	Ack_Valve OPEN
04/12/24 23:56:22	Trig_Valve OPEN
04/12/24 23:59:59	Rcv_Valve OPEN
04/12/25 00:00:01	Ack_Sensor4 Temp over

(GT11)

LINE A2 Alarm History	
10/12/05 10:02:34	RCV VALVE3 OK
10/12/05 10:01:12	SENSOR1 TEMP. STABLE
10/12/05 10:59:35	ACK VALVE3 OPEN.
10/12/05 00:59:01	TRIG VALVE3 OPEN.
10/12/05 10:59:58	TRIG SENSOR1 TEMP. OVER
10/12/05 09:59:17	ACK SECURITY COVER OK
10/12/05 09:57:43	ACK SECURITY COVER OPEN
10/12/05 09:57:32	TRIG SECURITY COVER OPEN

(GT21C)

### Transformer-isolated power supply

(GT05/GT32)

The isolated power supply enhances the reliability.

### Firmware upgrade

The display firmware is automatically upgraded when screen data is transferred. The firmware can be updated by downloading the latest version of Terminal GTWIN from our website (<http://www.mew.co.jp/ac/e/>).



# GT05M/GT05G

## Compact Programmable Display

Ultra-compact body equipped with a QVGA display capable of showing high quality images in the compact class

3.5 inch 

Pure black

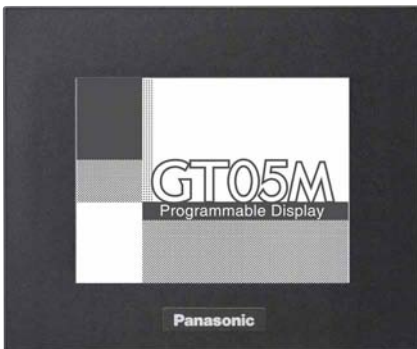

GT05M: white



GT05M: red



GT05M: pink

Hairline silver



GT05G: green



GT05G: orange



GT05G: red

**The 3.5-inch high-contrast monochrome QVGA LCD provides visibility ten times\*<sup>1</sup> better than our conventional model.**

Contrast ratio: 10 times\*<sup>1</sup> Displayable characters: 10 times\*<sup>1</sup> Resolution: 9 times\*<sup>1</sup>

**The new backlight provides three times higher brightness\*<sup>1</sup>. GT05M displays screens in white, pink and red, and GT05G in green, orange, and red, ensuring both operability and visibility.**

**SD memory card slot as standard equipment (1 GB max)**

Easy to copy, back up, and restore screen data.

**USB interface as standard equipment**

Supports the through function using a USB cable, allowing simultaneous debugging of PLC and GT

**Characters of a 240-dot maximum size can be displayed.**

Capable of displaying several fine ten-dot characters or one 240-dot character in full screen

**Transformer-isolated power supply**

The isolated power supply enhances the reliability.

Slot for SD memory card



Connector for communication and power supply

USB port



\*1: Compared with GT01

• The panel face protection sheet for the GT series is available as an option.

# GT05S

## Compact Programmable Display

The industry's smallest 3.5-inch STN color display capable of displaying colorful images in a limited space

3.5 inch 

Pure black



Hairline silver

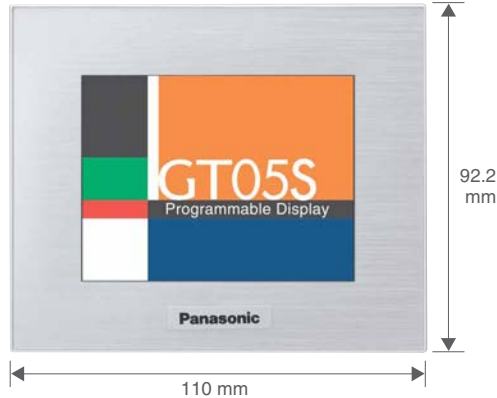

### 3.5-inch STN 4,096-color QVGA LCD with a wide viewing angle

Although the LCD is an STN type, a wide viewing angle (50 deg horizontally, 60 deg vertically) has been achieved, improving visibility from different angles.

### The new backlight provides twice the brightness\*2.

### SD memory card slot as standard equipment (1 GB max)

Easy to copy, back up, and restore screen data.

### USB interface as standard equipment

Supports the through function using a USB cable, allowing simultaneous debugging of PLC and GT

### Characters of a 240-dot maximum size can be displayed.

Capable of displaying several fine ten-dot characters or one 240-dot character in full screen

### Transformer-isolated power supply

The isolated power supply enhances the reliability.



\*1: Note that the COM port connector projects an additional 3.9 mm. Also take the cable diameter must be taken into account.

\*2: Compared with GT21C

• The panel face protection sheet for the GT series is available as an option.

# GT32M

## Programmable Display

Clear and beautiful display achieved by the blue LCD long-life backlight

5.7 inch



Pure black

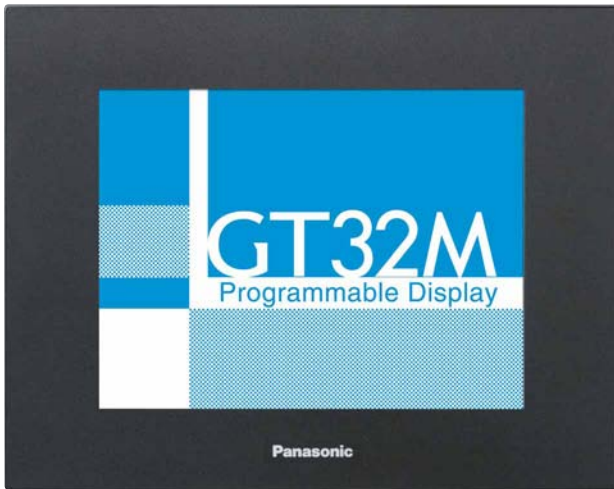

Hairline silver



## 5.7-inch blue LCD equipped with 75,000-hour long life backlight

Although the backlight is a CFL type, it can last as long as 75,000 hours (approx. 8.5 years), reducing maintenance frequency. \*1

## The industry's smallest size in the 5-inch class, and 39.1-mm thin and cool body design

Large display with space-saving outer dimensions of 163.2 x 128.8 x 39.1 mm

## SD memory card slot as standard equipment (1 GB max)

Easy to copy, back up, and restore screen data.

## USB interface as standard equipment

You can connect your PC and GT32 using your USB cable\*2 to transfer screen data.

When used with our FP series PLC, this display supports the through function, which allows simultaneous debugging of the PLC and the display.

## Transformer-isolated power supply

The isolated power supply enhances the reliability.



\*1: The backlight type for GT32M cannot be changed.

\*2: Please use a commercially available A-B type USB cable.

• The panel face protection sheet for the GT series is available as an option.

# GT32T0/T1

Programmable Display

Amazingly beautiful and vivid  
4,096-color TFT LCD

5.5 inch



Pure black

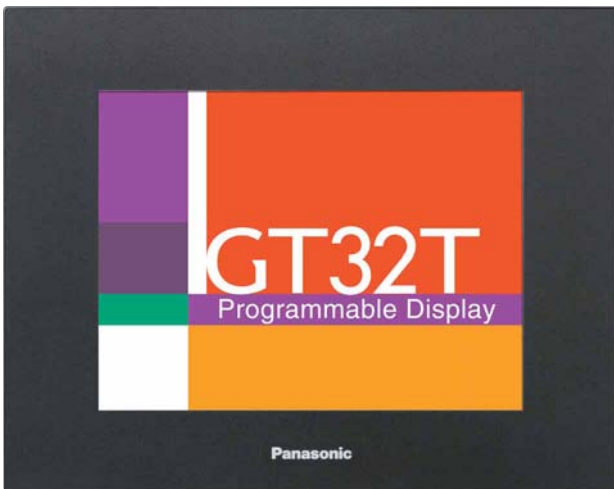

Hairline silver

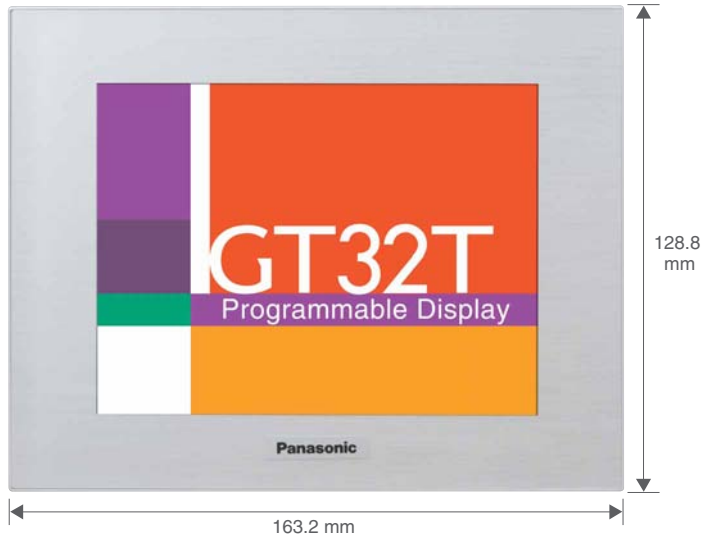

The 4,096-color TFT LCD screen displays magnificent quality images.

The industry's smallest size in the 5-inch class, and 39.1-mm thin and cool body design

**SD memory card slot as standard equipment (1 GB max)**

Useful for copying, backing up, and restoring screen data, and for saving sound files  
Sound files can also be saved in the internal memory of the display.

**USB interface as standard equipment**

**Transformer-isolated power supply**

**GT32T1 supports:**

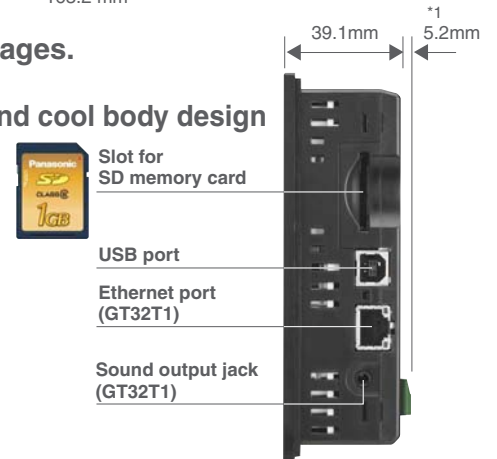

### Sound output function

Audio information as well as visual and tactile information allows for more reliable control by operators.

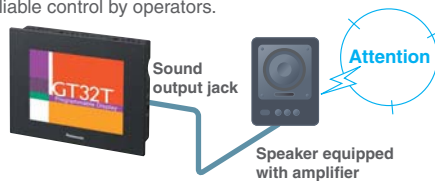

### Ethernet connection

GT32T1 supports Ethernet connection, allowing for the "through" function for our FP series PLC in a remote location.

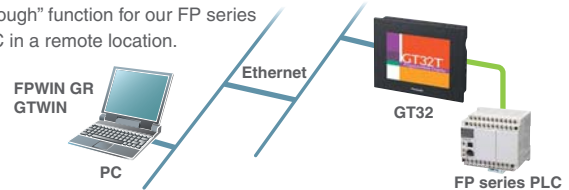

- 5.5 inch
- TFT 4,096 colors
- CFL backlight
- 32 chars. x24 lines (10-dot font)
- 320 x240 dots
- USB
- SD
- Ether net (GT32T1)
- Sound output (GT32T1)
- 24V DC

\*1: Note that the COM port connector projects an additional 5.2mm. Also take the cable diameter must be taken into account.  
• The panel face protection sheet for the GT series is available as an option.

# GT01

Ultra Compact Programmable Display

Ultra-compact 3-inch display with a full load of functions required for control panels

3 inch  

Black



Ash gray



Three-color backlight shows the equipment status.

Normal (Green)



In operation (Orange)

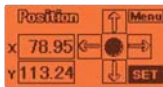

Emergency (Red)



Only one cable is required to connect your GT directly to our **FP series** or Mitsubishi Electric **FX series**, substantially reducing the man-hours for wiring. (5 V DC)

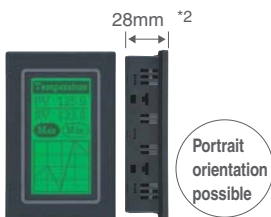

# GT01R

Ultra Compact Programmable Display

High-contrast clear display with excellent visibility achieved by the red and white backlight

3 inch  

Pure black



Hairline silver



Screens can be displayed in white, pink or red. Under normal conditions, the high-brightness white LED provides high visibility. During emergencies, the red LED allows you to check the status at a glance.

Normal (White)



Emergency (Red)



(Pink)



\*1: CE marking is not available for AIGT0032B1(H1) and AIGT0232B1(H1). \*2: When the panel thickness is 5 mm, the screw head of the mounting bracket protrudes 4 mm.  
• The panel face protection sheet for the GT series is available as an option.

# GT11

## Compact Programmable Display

The 4-inch wide screen equipped with a high-definition LCD can display a lot of information in its small space.

4 inch  

Black



Ash gray



Approx. doubled information capacity compared with GT10

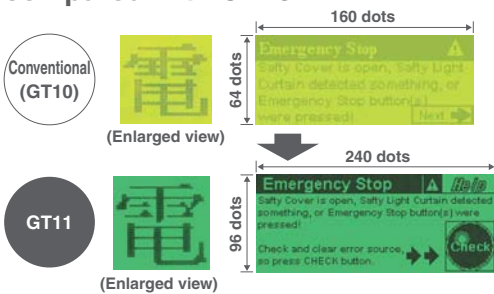

Three-color backlight shows the equipment status.

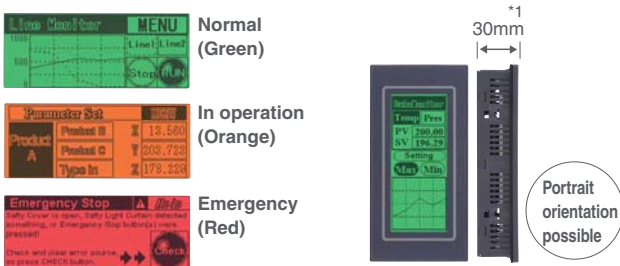



4 inch	STN monochrome (white/black)	3-color LED backlight (green/orange/red)	24 chars. x9 lines (10-dot font)	240 x96 dots	24V DC
--------	------------------------------	--	----------------------------------	--------------	--------

# GT21C

## Programmable Display

4.7-inch STN 256-color type.

The image vividness is equivalent to that of the 5.7-inch type display, which can be replaced with this model.

4.7 inch  

Pure black



Hairline silver

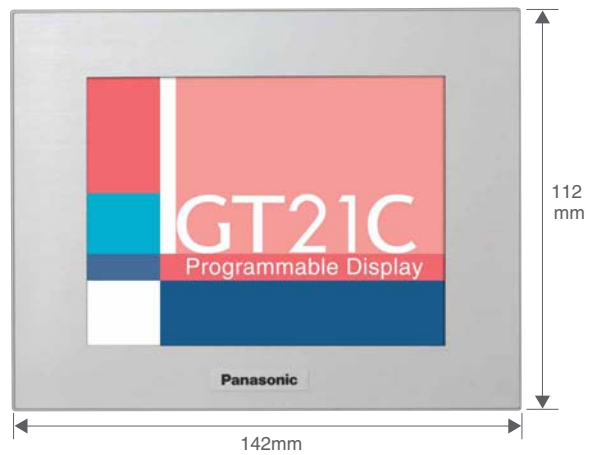

Maintenance-free white LED backlight

The total depth (excluding the display frame) is 29.9 mm, fitting a variety of installation locations.

Portrait orientation possible

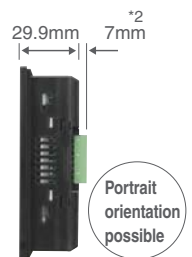

4.7 inch	STN 256 colors	White LED backlight	32 chars. x24 lines (10-dot font)	320 x240 dots	24V DC
----------	----------------	---------------------	-----------------------------------	---------------	--------

\*1: When the panel thickness is 5 mm, the screw head of the mounting bracket protrudes 4 mm.

\*2: Note that the COM port connector projects an additional 7mm. Also take the cable diameter must be taken into account.

• The panel face protection sheet for the GT series is available as an option.

# GTWIN Ver.2.9

Screen Creation Tool for the GT series

The user-friendly interface makes screen creation easier.

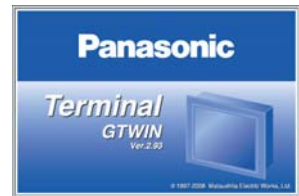

## Compatible with the eight languages for the menu

The menu can be indicated in Japanese/English/German/French/Spanish/Simplified Chinese/Korean/Italian.



## Just drag and drop your original parts to be registered.

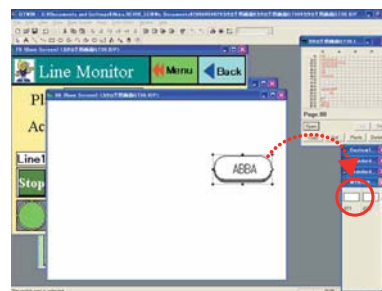

You can also register your preset original parts easily by drag-and-drop operations.

## Simply drag and drop parts.

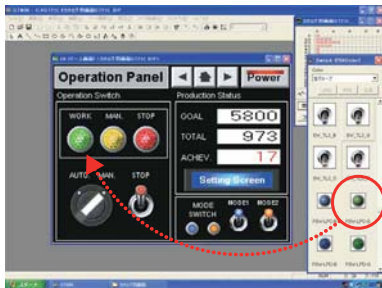

You can easily create screens by just dragging parts from the library and dropping them anywhere you want.

## 256-color 3D buttons (for GT05S/GT21C/GT32T)

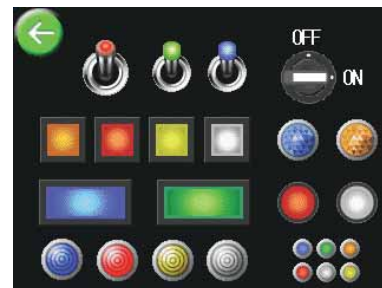

3D-design buttons with higher visibility and operability are available.

## More user-friendly parts libraries



In the previous version, the required parts library had to be selected from the menu every time it was needed. The new version displays a list of parts libraries, making them more user-friendly. You can also freely set the parts library window size.

## Screen copy in bitmap form

You can output screen images in bitmap form and use them in off-the-shelf applications. This is useful for preparing equipment operation manuals.

## Firmware upgrading function

Before transferring screen data, select "Automatic firmware update" to automatically upgrade the display if the display version is older than the firmware version in GTWIN. You can keep the firmware version upgraded by using the latest version of GTWIN.



\* Windows Vista®: The 64-bit version is not supported.

• GTWIN Ver. 2.8 or later is not compatible with Windows® 95, 98, Me or NT. Please use Ver. 2.71.

The difference file can be downloaded from our website: <http://www.mew.co.jp/ac/e/>

You can download a trial version of GTWIN Ver. 2 from our Website. (Registration is required.)

# GTseries | PLC Compatibility Table

Company	Series	Model	GT01/GT01R/GT05/GT11/GT21/GT32	
			RS232C type	RS422 (RS485) type*2
Matsushita Electric Works	FP series	FP-X	○	○
		FPΣ	○	○
		FP-e	○	○
		FP0	○	○
		FP2	○	○
		FP2SH	○	○
Mitsubishi Electric*1	FX series	FX0N	○	○
		FX1S	○	○
		FX1N	○	○
		FX1NC	○	○
		FX2N	○	○
		FX2NC	○	○
		FX3UC	○	○
		FX3U	○	○
	Q series	Q00CPU	○	
		Q01CPU	○	
		Q00JCPU	○	
		Q00HCPU	○	
		Q25HCPU	○	
		Q12HCPU	○	
		Q06HCPU	○	
		Q02HCPU	○	
	A series	A1N	○	
		A2N	○	
		A3N	○	
		A1S	○	
		A1SJ	○	
		A2SH	○	
		A1SH	○	
		A2CCPU24	○	
Omron*1	C series	C200H	○	
		C200HS	○	
		C500	○	
		C500F	○	
		C1000H	○	
		C2000	○	
		C2000H	○	
		C1000HF	○	
		C20H	○	
		C28H	○	
		C40H	○	
		C120	○	
		C120F	○	
		CQM1-CPU42	○	
		SRM1-C02	○	
		CPM2A	○	
		CPM1-20CDR-A	○	
		CQM1H-CPU21	○	
		CPM2C	○	
		CPM2B	○	
	α series	C200HE-CPU32-Z	○	
		C200HE-CPU32	○	
		C200HG-CPU33-Z	○	
		C200HG-CPU33	○	
		C200HG-CPU53-Z	○	
		C200HG-CPU53	○	
		C200HX-CPU34-Z	○	
		C200HX-CPU34	○	
		C200HX-CPU54-Z	○	
		C200HX-CPU54	○	
		C200HE-CPU42-Z	○	
		C200HE-CPU42	○	
		C200HG-CPU43-Z	○	
		C200HG-CPU43	○	
		C200HG-CPU63-Z	○	
		C200HG-CPU63	○	
C200HX-CPU44-Z	○			
C200HX-CPU44	○			
C200HX-CPU64-Z	○			
C200HX-CPU64	○			
C200HX-CPU65-Z	○			
C200HX-CPU85-Z	○			
CV series	CV500	○		
	CV1000	○		
	CVM1	○		

Models listed are the models that have been evaluated as of March, 2008.

Company	Series	Model	GT01/GT01R/GT05/GT11/GT21/GT32		
			RS232C type	RS422 (RS485) type*2	
Omron*1	CS1 series	CS1H-CPU67	○		
		CS1H-CPU66	○		
		CS1H-CPU65	○		
		CS1H-CPU64	○		
		CS1H-CPU63	○		
		CS1G-CPU45	○		
		CS1G-CPU44	○		
		CS1G-CPU43	○		
	CJ1 series	CJ1H	○		
		CJ1M	○		
	CP1 series	CP1H	○		
		CP1L	○		
Toshiba Machine*1	TC mini series		○	○	
Yokogawa Electric*1	FA-M3 series	F3SP59-7S	○		
		F3SP58-6S	○		
		F3SP58-6H	○		
		F3SP53-4S	○		
		F3SP53-4H	○		
		F3SP38-6S	○		
		F3SP38-6N	○		
		F3SP35-5N	○		
		F3SP28-3S	○		
		F3SP28-3N	○		
		F3SP25-2N	○		
		F3SP21-0N	○		
KEYENCE*1	KV series	KV-10/16/24/40	○		
		KV700		○	
		KV1000	○	○	
Hitachi	EH-150 EHV series	EHV-CPU128	○	○	
		EHV-CPU64	○	○	
		EHV-CPU32	○	○	
		EHV-CPU16	○	○	
	EH-150 series	EH-CPU104A	○	○	
		EH-CPU208A	○	○	
		EH-CPU316A	○	○	
		EH-CPU516	○	○	
	MICRO-EH series	EH-CPU548	○	○	
		10-point	○		
		14-point	○		
		20-point	○		
		23-point	○	○	
		28-point	○	○	
	Web Controller	40-point	○		
		64-point	○		
	ALLEN-BRADLEY*1	Micro Logic series	MicroLogix1000	○	
			SLC-500 series	SLC-5/03	○
Siemens*1	S7-200 series	SLC-5/04	○		
		CPU222	○	○	
		CPU216	○	○	
		CPU215	○	○	
LG*1	MASTER-K series	CPU214	○	○	
		CPU212	○	○	
		80S	○		
		200S	○		
Modbus*1	Models that support RTU protocol	300S	○		
		1000S	○		
		*3	○	○	
General-purpose serial	MEW dedicated protocol	*3	○	○	

\*1. PLCs other than Matsushita Electric Works FP series may be limited in the type of device that can be used and addresses. Please see manual for details.

\*2. Communication may not be possible when using RS485 depending on the sending and receiving timing with the other device.

\*3. We cannot specify what other device you should use; therefore, please test it using the actual equipment before using.

○: Direct connection is possible to the CPU unit of the PLC.

○: Connection is possible using the communications unit or a signal conversion cable, etc.

(Example: The QJ71C24N or QJ71C24N-R2 calculator link unit is required when using the Mitsubishi Q Series.)

×: Connection is not possible

Blank: Not evaluated.

Refer to the "Technical Support Page" of our website (<http://www.mew.co.jp/ac/e/>) for details, including the latest version of Terminal GTWIN, usable devices and addresses.





## Main Unit and Tool Software

Product name	Description				Part number
	LCD	Power supply	Communication port		
GT01	STN monochrome (green/orange/red, backlight)	5V DC	RS232C	Black	AIGT0030B1
				Ash gray	AIGT0030H1
			RS422 (RS485)	Black	AIGT0032B1
				Ash gray	AIGT0032H1
		24V DC	RS232C	Black	AIGT0030B
				Ash gray	AIGT0030H
RS422 (RS485)	Black	AIGT0032B			
	Ash gray	AIGT0032H			
GT01R	STN monochrome (white/pink/red, backlight)	5V DC	RS232C	Pure black	AIGT0230B1
				Hairline silver	AIGT0230H1
			RS422 (RS485)	Pure black	AIGT0232B1
				Hairline silver	AIGT0232H1
		24V DC	RS232C	Pure black	AIGT0230B
				Hairline silver	AIGT0230H
RS422 (RS485)	Pure black	AIGT0232B			
	Hairline silver	AIGT0232H			
GT05M	STN monochrome (white/pink/red, backlight)	24V DC	RS232C	Pure black	AIG05MQ02D
				Hairline silver	AIG05MQ03D
			RS422 (RS485)	Pure black	AIG05MQ04D
				Hairline silver	AIG05MQ05D
GT05G	STN monochrome (green/orange/red, backlight)	24V DC	RS232C	Pure black	AIG05GQ02D
				Hairline silver	AIG05GQ03D
			RS422 (RS485)	Pure black	AIG05GQ04D
				Hairline silver	AIG05GQ05D
GT05S	STN color	24V DC	RS232C	Pure black	AIG05SQ02D
				Hairline silver	AIG05SQ03D
			RS422 (RS485)	Pure black	AIG05SQ04D
				Hairline silver	AIG05SQ05D
GT11*1	STN monochrome (green/orange/red, backlight)	24V DC	RS232C	Black	AIGT2030B
				Ash gray	AIGT2030H
			RS422 (RS485)	Black	AIGT2032B
				Ash gray	AIGT2032H
GT21C	STN color	24V DC	RS232C	Pure black	AIGT2230B
				Hairline silver	AIGT2230H
			RS422 (RS485)	Pure black	AIGT2232B
				Hairline silver	AIGT2232H
GT32M	STN monochrome	24V DC	RS232C	Pure black	AIG32MQ02D
				Hairline silver	AIG32MQ03D
			RS422 (RS485)	Pure black	AIG32MQ04D
				Hairline silver	AIG32MQ05D
GT32T0	TFT color	24V DC	RS232C	Pure black	AIG32TQ02D
				Hairline silver	AIG32TQ03D
			RS422 (RS485)	Pure black	AIG32TQ04D
				Hairline silver	AIG32TQ05D
GT32T1	TFT color	24V DC	RS232C	Pure black	AIG32TQ12D
				Hairline silver	AIG32TQ13D
			RS422 (RS485)	Pure black	AIG32TQ14D
				Hairline silver	AIG32TQ15D
Terminal GTWIN Ver.2 Tool kit*2	English version	GTWIN CD-ROM GT Series Technical Manual (English version)			AIGT8001V2
Terminal GTWIN Upgrade version*2	English version	Upgrades Terminal GTWIN Ver. 1 to Ver. 2.			AIGT8001V2R

\*1: For GT11, a white LED backlight type is also available (made-to-order). Replace the sixth digit of the Part No. with "1" to order it. (Example: AIGT2130B)

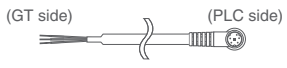
\*2: GTWIN Ver. 2.8 or later is not compatible with Windows® 95, 98, Me or NT. Please use Ver. 2.71. The difference file can be downloaded from our website: <http://www.mew.co.jp/ac/e/>

Cables | PLC connection cable

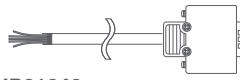
Programmable Display	Connection cable	PLC
GT01/GT01R (5V DC, RS232C)	 <p>Part No.: <b>AIGT8142*</b>, PLC connection cable (2 m), 5-pin mini-DIN connector — 4 single wires + Shielding wire</p>	Matsushita Electric Works FP Series
GT01/GT01R (5V DC, RS422/RS485)	 <p>Part No.: <b>AIGT8152*</b>, PLC connection cable (2 m), 8-pin mini-DIN connector — 6 single wires + Shielding wire</p>	Mitsubishi Electric FX Series
GT series (24V DC, RS232C)	 <p>Part No.: <b>AIGT8162</b>, PLC connection cable (2 m), 5-pin mini-DIN connector — 3 single wires + Shielding wire AIGT8165 (5 m) and AIGT8160 (10 m) are also available.</p>	Matsushita Electric Works FP Series
GT series (24V DC, RS422/RS485)	 <p>Part No.: <b>AIGT8175</b>, PLC connection cable (5 m), 8-pin mini-DIN connector — 4 single wires + Shielding wire</p>	Mitsubishi Electric FX Series
GT series (24V DC, RS232C)	 <p>Part No.: <b>AIP81842</b>, PLC connection cable (2 m), 9-pin D-SUB connector — open wire</p>	Matsushita Electric Works FP2/FP2SH COM port, 9-pin D-SUB connector example, CCU

\*This cable is for GT01/GT01R, and power is supplied through the TOOL port.

Screen data transmission cable (for DOS/V computers)



9-pin D-SUB connector —  
5-pin mini-DIN connector (L type: 3 m)  
Part No.: **AFC8503**



9-pin D-SUB connector —  
5-pin mini-DIN connector (Straight type: 3 m)  
Part No.: **AFC8503S**

Tool port panel extension cable



Part No.: **AFC8532**

\*For GT05/GT32, please use a commercially available A-B type USB cable.

- Different part numbers are applied to the cables available for Europe. Please refer to <http://www.panasonic-electric-works.com/>
- Different part numbers are applied to the cables available for North, Central and South Americas. Please refer to <http://pewa.panasonic.com/acsd/>

Options

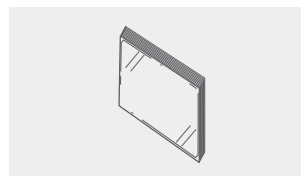

■ **Panel face protection sheets**  
10 sheets in a set (option)

GT01	Part No.: <b>AIGT080</b>
GT01R	Part No.: <b>AIGT080R</b>
GT05	Part No.: <b>AIG05800</b>
GT11	Part No.: <b>AIGT280</b>
GT21	Part No.: <b>AIGT28021</b>
GT32	Part No.: <b>AIG32800</b>

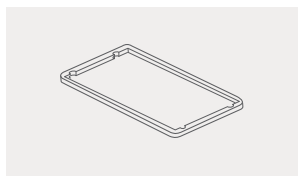

■ **Waterproof packing**  
Waterproof packing (for replacement), 10 pieces in a set  
Package includes one set. One set is installed on main unit.

GT01, GT01R	Part No.: <b>AIGT081</b>
GT05	Part No.: <b>AIG05810</b>
GT11	Part No.: <b>AIGT181</b>
GT21	Part No.: <b>AIGT28121</b>
GT32	Part No.: <b>AIG32810</b>

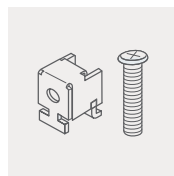

■ **GT01/GT01R/GT11 mounting parts**  
5 sets of mounting parts (4 parts/set)  
Package includes one set. One set is installed on main unit.

Part No.: **AIGT083**

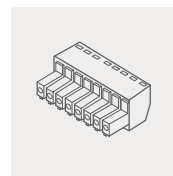

■ **Spare connector**  
COM. port connectors, 5 connectors in a set  
One set is installed on main unit.

Part No.: **AIGT084**

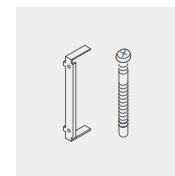

■ **GT05/GT21C/GT32 mounting parts**  
5 sets of GT05/GT21C/GT32 mounting parts (2 parts/set)  
Package includes one set. One set is installed on main unit.

GT05/GT21C  
Part No.: **AIGT28321**

GT32  
Part No.: **AIG32830**

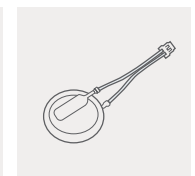

■ **GT05/GT32 backup battery**  
\* For GT11 and GT21C, please purchase a commercially available CR2032 battery.

Part No.: **AFPX-BATT**

Item	GT01 / GT01R				GT05M / GT05G		GT05S		GT11		
	5V/RS232C	5V/RS422	24V/RS232C	24V/RS422	RS232C	RS422	RS232C	RS422	RS232C	RS422	
Rated voltage	5 V DC				24 V DC						
Operating voltage range	4.5 to 5.5 V DC				21.6 to 26.4 V DC						
Power consumption	1W max.	1.1W max.	2W max.		2.4W max.		3.6W max.		2.4W max.		
Power supply unit isolation method	—				Transformer isolation				—		
Ambient temperature	0 to 50°C								0 to 50°C <sup>1</sup>		
Ambient humidity	20 to 85% RH (No condensation at 25°C)										
Storage temperature	-20 to 60°C										
Storage humidity	10 to 85% RH (No condensation at 25°C)										
Vibration resistance	10 to 55 Hz (1-minute cycle): Double amplitude: 0.75 mm, 10 minutes in each of the X, Y, and Z directions										
Shock resistance	98 m/s <sup>2</sup> min: 4 times in each of the X, Y, and Z directions										
Superposed noise suppression	1,000 V [P-P] min, pulse width of 50 ns, 1 μs between power supply terminals (by a noise simulator) *AIGT0030B1/AIGT0030H1: When the ferrite device supplied with our PLC connection cable (AIGT8142) is mounted										
Environmental resistance	IP65 (in the initial stages) Dust-proof and drip-proof from the front of the panel only (Rubber packing is attached to the panel contact surface.) *When reattaching the panel, replace the waterproof packing.										
Mass	Approx. 160 g				Approx. 230 g						
Display	Display device	STN monochrome LCD				STN monochrome LCD		STN color LCD		STN monochrome LCD	
	Resolution	128 (W) x 64 (H) dots				320 (W) x 240 (H) dots				240 (W) x 96 (H) dots	
	Display color	2 colors (black/white)				2 colors (black/white)		4,096 colors		2 colors (black/white)	
	Displayable area	70.38 (W) x 35.18 (H) mm				73.0 (W) x 55.2 (H) mm				96.0 (W) x 38.4 (H) mm	
	Backlight	GT01: 3-color LED (green, orange, red) GT01R: 3-color LED (white, pink, red) *No need for replacement				GT05M: 3-color LED (white, pink, red) GT05G: 3-color LED (green, orange, red) *No need for replacement		White LED *No need for replacement		3-color LED (green, orange, red)/White LED *No need for replacement	
Functions	Font types	Fixed (GTWIN) : 8 x 8, 16 x 8, and 16 x 16 dots Characters can be displayed in the 1, 2, 4, or 8 times width or height. TrueType (GTWIN): 10 to 64 dots				Fixed (GTWIN) : 8 x 8, 16 x 8, and 16 x 16 dots, Characters can be displayed in the 1, 2, 4, or 8 times width or height, TrueType (GTWIN): 10 to 240 dots, Windows®: 10 to 240 dots				Fixed (GTWIN) : 8 x 8, 16 x 8, and 16 x 16 dots Characters can be displayed in the 1, 2, 4, or 8 times width or height. TrueType (GTWIN): 10 to 64 dots	
	Languages	Japanese, English, Korean, German, French, Spanish, Italian, Simplified Chinese, Traditional Chinese, Turkish									
	Graphics	Straight lines, continuous straight lines, squares, circles, ovals, arcs, elliptic arcs, fan shapes, elliptic fan shapes, beveled squares, bitmaps									
	Number of screens <sup>4</sup>	Approx. 160 screens				Approx. 240 screens		Approx. 180 screens		Approx. 250 screens	
	Screen No. that can be set	Base screens: No. 0 to 3FF, Keyboard screens: No. 0 to 7									
	Part functions	Messages, lamps, switches, data, bar graphs, clocks, keyboards, and line graphs				Messages, lamps, switches, data, bar graphs, clocks, keyboards, line graphs, and alarm list parts					
	Other functions	Recipe, flow display, write device, and language switching				Recipe, flow display, write device, alarm record, alarm list, and language switching					
	Clock function	Refers to and displays external clock data. (Not provided with a built-in clock function.)				Provided with a built-in clock function. (Can also refer to and display a PLC clock.) *Buy a commercially available battery.					
	Contrast adjustment	Contrast can be adjusted by using the touch panel.									
	Automatic communication settings	The communication speed (baud rate) is automatically changed if there is no response from the target equipment.									
	Debugging function	GT connected between a PC and PLC allows the PLC to be debugged without a direct connection with the PC.									
	Screen creation	Dedicated software should be used. Applicable OS: Windows® 95 (OSR2 or later)/ 98/Me/2000/NT/XP/Vista				Dedicated software should be used. Applicable OS: Windows® 2000/XP/Vista				Dedicated software should be used. Applicable OS: Windows® 95 (OSR2 or later)/ 98/Me/2000/NT/XP/Vista	
Touch key resolution	Free layout (8 dots min.)										
Touch key operation force	0.5 N max.				0.8 N max.				0.5 N max.		
Touch key life	1 million operations min. (at 25°C)										
COM. Port	Communication standard	Conforms to RS232C	Conforms to RS422	Conforms to RS232C	Conforms to RS422	Conforms to RS232C	Conforms to RS422	Conforms to RS232C	Conforms to RS422	Conforms to RS422	
	External communication conditions	Baud rate: 9,600/19,200/38,400/57,600/115,200 bps									
	Protocol	Data bits: 7 or 8 bits, Parity: None, Odd, Even, Stop bits: 1 bit									
	Connector	Our FP series supported/General-purpose serial interface supported/Other companies' PLC supported (Refer to the compatible PLC list for manufacturers and models.)									
Screen data transfer interface	Communication standard	Tool port (Conforms to RS232C)				USB1.1				Tool port (Conforms to RS232C)	
	Communication conditions with personal computers	Baud rate: 9,600/19,200/115,200/230,400 bps*6 Data bits: 8 bits, Parity: None, Odd, Even, Stop bits: 1 bit				—				Baud rate: 9,600/19,200/115,200/230,400 bps*6 Data bits: 8 bits, Parity: None, Odd, Even, Stop bits: 1 bit	
	Protocol	Our dedicated protocol									
	Connector	5-pin mini-DIN				USB TYPE-B				5-pin mini-DIN	
	Ethernet port <sup>8</sup>	—									
User's memory	F-ROM										
Memory capacity	384 kbyte				2 Mbyte		12 Mbyte		1.375 Mbyte		
Memory	—										
Memory backup	—										
	Lithium battery (replaceable) AFPX-BATT *Does not come with product.										
	Lithium battery (replaceable) CR2032, commercially available *Does not come with product.										

## Conformance to the UL/cUL standards

UL/cUL file No.	E96300
UL Standard No.	UL508

Item	GT21C		GT32M		GT32T0		GT32T1		
	RS232C	RS422	RS232C	RS422	RS232C	RS422	RS232C	RS422	
Rated voltage	24 V DC								
Operating voltage range	21.6 to 26.4 V DC								
Power consumption	4.8W max.		10W max.			12W max.			
Power supply unit isolation method	—		Transformer isolation						
Ambient temperature	0 to 50°C*2		0 to 50°C*3						
Ambient humidity	20 to 85% RH (No condensation at 25°C)								
Storage temperature	-20 to 60°C								
Storage humidity	10 to 85% RH (No condensation at 25°C)								
Vibration resistance	10 to 55 Hz (1-minute cycle): Double amplitude: 0.75 mm, 10 minutes in each of the X, Y, and Z directions								
Shock resistance	98 m/s <sup>2</sup> min: 4 times in each of the X, Y, and Z directions								
Superposed noise suppression	1,000 V [P-P] min, pulse width of 50 ns, 1 μs between power supply terminals (by a noise simulator)								
Environmental resistance	IP65 (in the initial stages) Dust-proof and drip-proof from the front of the panel only (Rubber packing is attached to the panel contact surface.) *When reattaching the panel, replace the waterproof packing.								
Mass	Approx. 330 g		Approx. 500 g		Approx. 470 g		Approx. 480 g		
Display	Display device	STN color LCD		STN monochrome LCD		TFT color LCD			
	Resolution	320 (W) x 240 (H) dots							
	Display color	256 colors		2 colors (blue/white)		4,096 colors			
	Displayable area	98.0 (W) x 74.0 (H) mm		113.2 (W) x 86.4 (H) mm		110.8 (W) x 83.6 (H) mm			
	Backlight	White LED *No need for replacement		CFL *Not replaceable. Average life: GT32M: 75,000 hours (at 25°C), GT32T: 50,000 hours (at 25°C)					
Functions	Font types	Fixed (GTWIN) : 8 x 8, 16 x 8, and 16 x 16 dots, Characters can be displayed in the 1, 2, 4, or 8 times width or height, TrueType (GTWIN): 10 to 240 dots, Windows®: 10 to 240 dots							
	Languages	Japanese, English, Korean, German, French, Spanish, Italian, Simplified Chinese, Traditional Chinese, Turkish							
	Graphics	Straight lines, continuous straight lines, squares, circles, ovals, arcs, elliptic arcs, fan shapes, elliptic fan shapes, beveled squares, bitmaps							
	Number of screens*4	Approx. 250 screens		Approx. 240 screens		Approx. 180 screens			
	Screen No. that can be set	Base screens: No. 0 to 3FF, Keyboard screens: No. 0 to 7							
	Part functions	Messages, lamps, switches, data, bar graphs, clocks, keyboards, line graphs, and alarm list parts							
	Other functions	Recipe, flow display, write device, alarm record, alarm list, and language switching					Sound output *5		
	Clock function	Provided with a built-in clock function. (Can also refer to and display a PLC clock.) *Buy a commercially available battery.							
	Contrast adjustment	Contrast can be adjusted by using the touch panel.				Not adjustable			
	Automatic communication settings	The communication speed (baud rate) is automatically changed if there is no response from the target equipment.							
	Debugging function	GT connected between a PC and PLC allows the PLC to be debugged without a direct connection with the PC.							
	Screen creation	Dedicated software should be used. Applicable OS: Windows® 95 (OSR2 or later)/ 98/Me/2000/NT/XP/Vista		Dedicated software should be used. Applicable OS: Windows® 2000/XP/Vista					
Touch key resolution	Free layout (8 dots min.)								
Touch key operation force	0.8 N max.								
Touch key life	1 million operations min. (at 25°C)								
COM. Port	Communication standard	Conforms to RS232C	Conforms to RS422	Conforms to RS232C	Conforms to RS422	Conforms to RS232C	Conforms to RS422	Conforms to RS232C	Conforms to RS422
	External communication conditions	Baud rate: 9,600/19,200/38,400/57,600/115,200 bps							
	Protocol	Data bits: 7 or 8 bits, Parity: None, Odd, Even, Stop bits: 1 bit							
	Connector	Our FP series supported/General-purpose serial interface supported/Other companies' PLC supported (Refer to the compatible PLC list for manufacturers and models.) Connector terminal base (8 pins)							
Screen data transfer interface	Communication standard	Tool port (Conforms to RS232C)		USB1.1					
	Communication conditions with personal computers	Baud rate: 9,600/19,200/115,200/230,400 bps*6 Data bits: 8 bits, Parity: None, Odd, Even, Stop bits: 1 bit		—					
	Protocol	Our dedicated protocol							
	Connector	5-pin mini-DIN		USB TYPE-B					
Ethernet port*9	—		Yes (100BASE-TX, 10BASE-T) *7, *8						
User's memory	F-ROM								
Memory capacity	6.5 Mbyte		2 Mbyte		12 Mbyte (Ver.1.10 or later)				
Memory	SRAM								
Memory backup	Lithium battery (replaceable) CR2032, commercially available *Does not come with product.		Lithium battery (replaceable) AFPX-BATT *Does not come with product.						

\*1. When the unit is being installed in a portrait orientation or FP programmer II is being connected to the TOOL port, the usable range is 0 to +45°C.  
\*2. When the unit is being installed in a horizontal orientation or FP programmer II is being connected to the TOOL port, the usable range is 0 to +45°C.  
\*3. When the unit is being installed in a horizontal orientation, the usable range is 0 to +40°C.  
\*4. The number of screens that can be registered varies according to the registered contents.  
\*5. WAV format (PCM, 8-KHz sampling rate, 16 bits, mono), Maximum sound data capacity: 512 KB (approx. 30 sec), Maximum registrable number of sound data items: 128

\*6. A USB/RS232C conversion cable should be used to achieve a communication speed of 230,400 bps.  
When the TOOL port of GT is set to 230,400 bps, the auto communication setting function of GTWIN cannot be used. Set the communication speed to 230,400 bps on GTWIN before transferring data.  
\*7. The unit carries out serial communication data processing at 115.2kbts/s.  
\*8. Communications with external equipment (PLC) are not available.  
\*9. Simultaneous USB and Ethernet communications are not possible.

GT01/GT01R

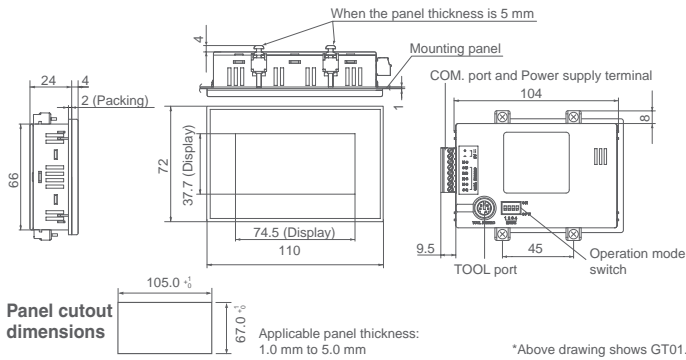

GT05M/GT05G/GT05S

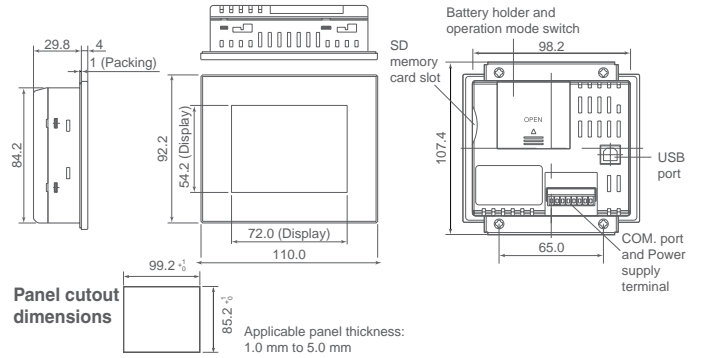

GT11

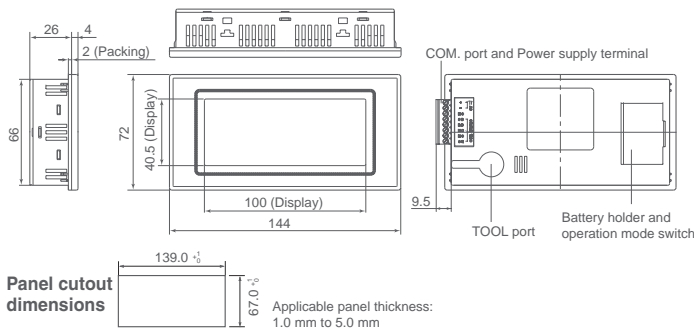

GT21C

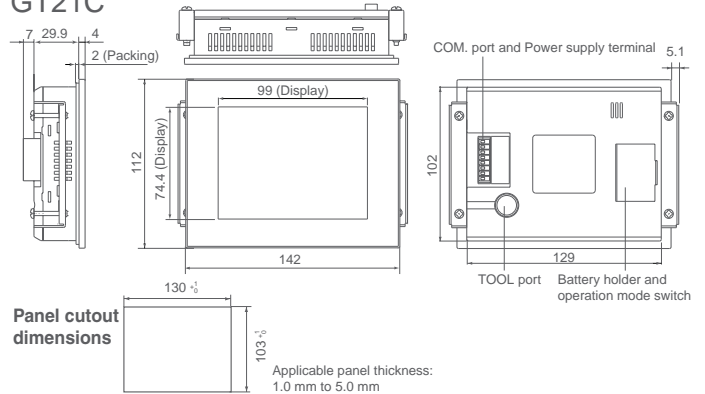

GT32M/GT32T

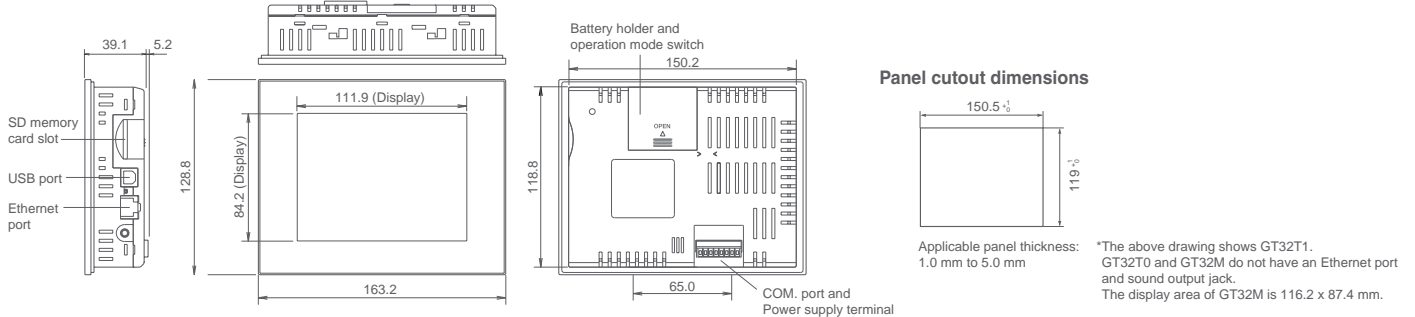

- Windows® is a registered trademark of the Microsoft Corporation.
- Ethernet is a registered trademark of Xerox Corporation.

Please contact .....

Matsushita Electric Works, Ltd.

Automation Controls Business Unit

■ Head Office: 1048, Kadoma, Kadoma-shi, Osaka 571-8686, Japan

■ Telephone: +81-6-6908-1050 ■ Facsimile: +81-6-6908-5781

<http://www.mew.co.jp/ac/el>

**Panasonic**®

All Rights Reserved © 2008 COPYRIGHT Matsushita Electric Works, Ltd.