

FX-11A

Slim Body Analog Fiber Sensor



Analog output type for diverse applications

Analog voltage output

It incorporates an analog voltage output of 1 to 5 V.

Various uses

In combination with various types of fibers and the ultra-compact digital panel controller, **CA2** series or the digital panel controller **CA** series, **FX-11A** can be used for various applications, such as, height evaluation, level detection by differential sensing, etc.

Saturation indicator

The saturation indicator lights up when the output reaches 5 V. Hence, the sensitivity can be easily adjusted even without using a tester. Moreover, an incident beam indicator which brightens up in proportion to the amount of incident beam (output voltage) is also incorporated.

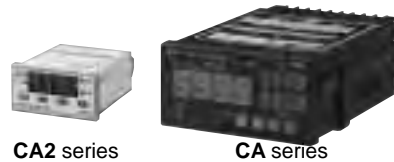

CA2 series

CA series

Digital panel controller

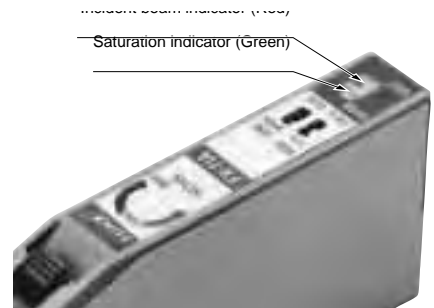

Incident beam indicator (Grey)
Saturation indicator (Green)

Interference prevention function

Two sets of fibers can be mounted close together or face to face.

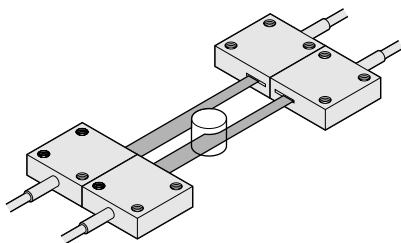

Slim size

Being only 10 mm 0.394 in thick, it can be mounted in a narrow space.

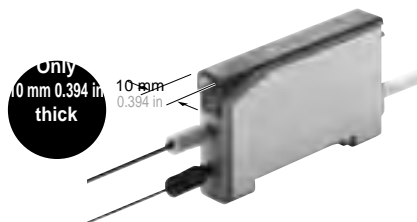

APPLICATIONS

Evaluating height of traveling objects

Objects can be sorted according to their height.

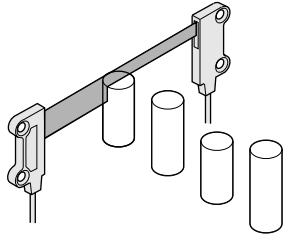

Detecting level difference

When differential sensing is used, no sensitivity readjustment is required even if the reflectivity of the objects changes.

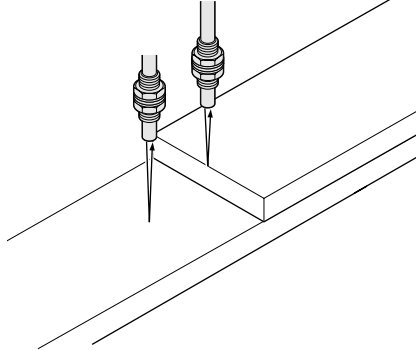

Detecting product mix-up

Mixed-up products that differ in color (reflectivity) can be sorted out from normal products.

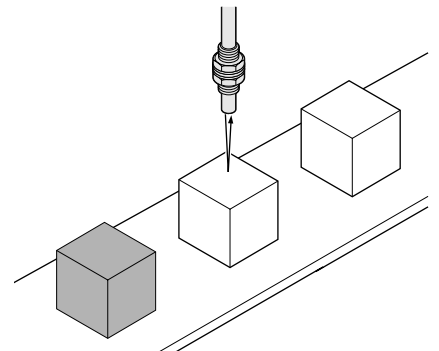

Ascertaining the number of translucent films

The number of overlapping translucent films can be ascertained.

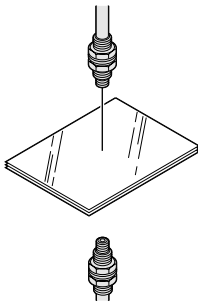

Sensing turbidity of liquid

The turbidity of a liquid inside a clear-wall tank can be sensed in an analog manner.

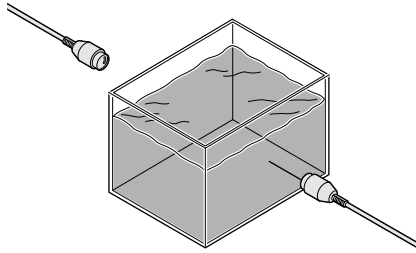

Measuring inner diameter of rings

Rings can be sorted according to their inner diameter.

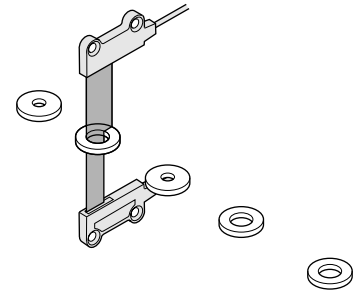

Fiber Selection

FX-301

FX-302

FX-303

Bank Selection Unit

FX-CH

Manually Set

FX-311

Analog Output

FX-11A

Color Detection

FZ-10

FX-11A

ORDER GUIDE

Amplifier

| Appearance | Model No. | Supply voltage | Analog output |
|---|---------------|--------------------------|--|
|  | FX-11A | 12 to 24 V DC \pm 10 % | Analog voltage • Output voltage: 1 to 5 V |

Accessory

- MS-DIN-2 (Amplifier mounting bracket)

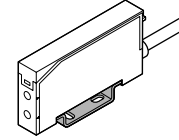

Fibers [Thru-beam type (one pair set)]

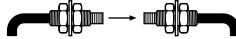





























| Type | Shape of fiber head (mm in) | Sensing range (Note 1) | Features | Fiber cable length ✂ : free cut | Model No. | |
|--------------------|---|---|--|--|--|---------------|
| Long sensing range | Lens mountable → M4 | 160 mm 6.299 in | • Twice the sensing range for the same diameter | ✂ | FT-B8 | |
| | With lens → ϕ 2.5 ϕ 0.098 | 125 mm 4.921 in | • Long sensing range with small fiber heads of ϕ 2.5 mm ϕ 0.098 in | ✂ | FT-SFM2L | |
| Standard | Lens mountable → M4 | 85 mm 3.346 in | • Free-cut type | ✂ | FT-FM2 | |
| | With sleeve | | | | FT-FM2S With sleeve 90 mm 3.543 in | |
| | → M4 | | | | FT-FM2S4 With sleeve 40 mm 1.575 in | |
| | → ϕ 2.5 ϕ 0.098 | | | | FT-SFM2 | |
| | Lens mountable → M3 | | | | FT-T80 | |
| Thru-beam | → M3 | 23 mm 0.906 in | • Suitable for detection in a congested equipment • Free-cut type | ✂ | FT-NFM2 | |
| | With sleeve → M3 | | | | FT-NFM2S With sleeve 90 mm 3.543 in | |
| | → ϕ 0.88 ϕ 0.035 | | | | FT-NFM2S4 With sleeve 40 mm 1.575 in | |
| | → ϕ 1.5 ϕ 0.059 | | | | FT-SNFM2 | |
| Sharp bend | With lens → ϕ 3 ϕ 0.118 | 100 mm 3.937 in | • The fiber can be bent sharply, like an electric wire, to avoid space wastage in installation because of its small allowable bending radius of R1 mm R0.039 in or more. | ✂ | FT-WS8L | |
| | Lens mountable → M4 | 35 mm 1.378 in | | | FT-W8 | |
| | → ϕ 2.5 ϕ 0.098 | | | | FT-WS8 | |
| | Small diameter → M3 | | | | 8 mm 0.315 in | FT-W4 |
| | → ϕ 1.5 ϕ 0.059 | | | | | FT-WS4 |
| Special use | Wide beam W4.2 × H31 × D13.5 W0.165 × H1.220 × D0.531 | | 100 mm 3.937 in | • The wide beam detects an object at any place within the range. | ✂ | FT-A8 |
| | Array | Top sensing → \square 15 \square 0.591 | 65 mm 2.559 in | ✂ | FT-AFM2 | |
| | | Side sensing → \square 15 \square 0.591 | | | FT-AFM2E | |

Note: The sensing range is defined as the range until the saturation indicator lights up.

ORDER GUIDE

Fibers [Reflective type] 

| Type | Shape of fiber head (mm in) | Sensing range (Note 1) | Features | Fiber cable length  : free cut | Model No. | | |
|----------------|-----------------------------|---|--|--|---|--|---|
| Reflective | Long sensing range |  M6 | 31 mm 1.220 in | • Long sensing range |  : free cut | FD-B8 | |
| | | Coaxial M6 | | | | FD-FM2 | |
| | Standard | With sleeve |  M6 | 22 mm 0.866 in | • Free-cut type |  : free cut | FD-FM2S With sleeve 90 mm 3.543 in |
| | | |  M6 φ2.5 φ0.098 | | | | FD-FM2S4 With sleeve 40 mm 1.575 in |
| | |  M4 | 22 mm 0.866 in | • Miniature head but having the same sensing range as the standard type fiber |  : free cut | FD-T80 | |
| | |  M3 | 7 mm 0.276 in | | | FD-T40 | |
| | |  Small diameter φ3 φ0.118 | 22 mm 0.866 in | | | FD-S80 | |
| | |  M4 | | | | FD-NFM2 | |
| | | With sleeve |  M4 | 7 mm 0.276 in | • Suitable for detection in a congested equipment • Free-cut type |  : free cut | FD-NFM2S With sleeve 90 mm 3.543 in |
| | | |  M4 φ1.48 φ0.058 | | | | FD-NFM2S4 With sleeve 40 mm 1.575 in |
| | | |  φ2.5 φ0.098 | | | | FD-SNFM2 |
| | | | | | | | |
| | Sharp bend | Standard |  M6 | 8 mm 0.315 in | • The fiber can be bent sharply, like an electric wire, to avoid space wastage in installation because of its small allowable bending radius of R1 mm R0.039 in or more (FD-WG4, FD-WSG4: R2 mm R0.079 in or more). |  : free cut | FD-W8 |
| | | |  M4 | 8 mm 0.315 in | | | FD-WT8 |
| | | |  φ3 φ0.118 | | | | FD-WS8 |
| High precision | |  Coaxial M4 | 3 mm 0.118 in | FD-WG4 | | | |
| | |  Lens mountable M4 | | FD-WSG4 | | | |
| | |  Coaxial φ3 φ0.118 | | | | | |
| | | | | | | | |
| Special use | Array |  Top sensing | 13 mm 0.512 in | • Its wide beam meets various needs. |  : free cut | FD-AFM2 | |
| | |  Side sensing | | | | FD-AFM2E | |
| | High precision |  Coaxial M4 | 10 mm 0.394 in | • Precise position sensing with coaxial fiber |  : free cut | FD-G4 | |
| | |  Lens mountable M4 | | | | | |
| | |  Coaxial • Small head | 3 mm 0.118 in | • Combination with the FX-MR3 lens gives an extremely small spot diameter of φ0.3 mm φ0.012 in approx. | 500 mm 19.685 in | FD-EG1 | |

Notes: 1) The sensing range is defined as the range until the saturation indicator lights up.

Further, for the reflective type fibers, it is specified for white non-glossy paper [50 × 50 mm 1.969 × 1.969 in (FD-B8: 100 × 100 mm 3.937 × 3.937 in)] as the object.

2) Please take care that the sensing range of free-cut type fiber may be reduced by 20 % max.

Accessories

• MS-DIN-2
(Amplifier mounting bracket)

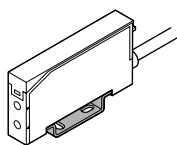

• FX-CT2
(Fiber cutter)

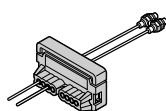

• FX-AT10
(φ1 mm φ0.039 in fiber attachment)

• FX-AT13
(φ1.3 mm φ0.051 in fiber attachment)

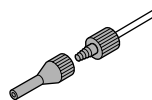

Fiber Selection

FX-301

Digital Setting
FX-302

FX-303

Bank Selection Unit
FX-CH

Manually Set
FX-311

Analog Output
FX-11A

Color Detection
FZ-10

OPTIONS

| Designation | | Model No. | Description | | |
|---|-----------------------------------|--|--|-----------------------------------|--|
| For thru-beam type fiber | Expansion lens | FX-LE1 | Increases the sensing range by 6 times or more. • Sensing range (Lens on both sides) (Note 1): 900 mm 35.433 in (FT-B8), 750 mm 29.528 in (FT-FM2, FT-T80), 350 mm 13.780 in (FT-W8) | | |
| | Super-expansion lens | FX-LE2 | Tremendously increases the sensing range with large aperture lenses. • Sensing range (Lens on both sides) (Note 1): 3,000 mm 118.110 in (FT-B8), 2,500 mm 98.425 in (FT-FM2), 3,000 mm 118.110 in (FT-W8) | | |
| | Side-view lens | FX-SV1 | Beam axis is bent by 90°. • Sensing range (Lenses on both sides) (Note 1): 220 mm 8.661 in (FT-B8), 200 mm 7.874 in (FT-FM2, FT-T80), 25 mm 0.984 in (FT-W8) | | |
| For reflective type fiber | Pinpoint spot lens | FX-MR1 | Pinpoint spot of $\phi 0.5$ mm $\phi 0.020$ in. • Applicable fiber: FD-WG4, FD-G4 • Distance to focal point: 6 ± 1 mm 0.236 ± 0.039 in | | |
| | Zoom lens | FX-MR2 | The spot diameter is adjustable from $\phi 0.7$ to $\phi 2$ mm $\phi 0.028$ to $\phi 0.079$ in according to how much the fiber is screwed in. • Applicable fiber: FD-WG4, FD-G4 • Distance to focal point: 18.5 to 43 mm 0.728 to 1.693 in approx. (Screw-in depth: 7 to 14 mm 0.276 to 0.551 in) • Spot diameter: $\phi 0.7$ to $\phi 2$ mm $\phi 0.028$ to $\phi 0.079$ in (Screw-in depth: 7 to 14 mm $\phi 0.276$ to $\phi 0.551$ in) | | |
| | Finest spot lens | FX-MR3 | Extremely fine spot of $\phi 0.3$ mm $\phi 0.012$ in is achieved. • Applicable fiber: FD-WG4, FD-EG1, FD-G4 • Distance to focal point: 7.5 ± 0.5 mm 0.295 ± 0.020 in • Spot diameter: $\phi 0.3$ mm $\phi 0.012$ in (FD-EG1), $\phi 0.5$ mm $\phi 0.020$ in (FD-WG4, FD-G4) | | |
| Digital panel controller (Note 2) | CA2-T2 | NPN open-collector transistor | This is a very small controller which allows two independent threshold level settings. • Supply voltage: 24 V DC $\pm 10\%$ • No. of inputs: 1 No. (sensor input) • Input range: 1 to 5 V DC • Main functions: Threshold level setting function, zero-adjust function, scale setting function, hysteresis setting function, start / hold function, auto-reference function, power supply ON-delay function, etc. | | |
| | CA-R2 | Relay contact | This is a multi-functional controller having mathematical functions, hold function, etc. • Supply voltage: 100 to 240 V AC $\pm 10\%$ • No. of inputs: 2 Nos. (sensor inputs) • Input range: 1 to 5 V DC • Power supply for sensor: 12 V DC, 150 mA • Main functions: Mathematical functions, process number selection function, hold function, scaling function, auto-reference function, power supply ON-delay function, measurement start delay function, hysteresis setting function, etc. | | |
| | CA-T2 | NPN open-collector transistor | | | |
| | CA-B2 | NPN open-collector transistor With BCD output | | | |
| Protective tube (For thru-beam type fiber) | FTP-500 (0.5 m 1.640 ft) | For M4 thread | Applicable fibers | FT-B8 | The protective tube, made of non-corrosive stainless steel, protects the inner fiber cable from any external forces. |
| | FTP-1000 (1 m 3.281 ft) | | | FT-FM2 | |
| | FTP-1500 (1.5 m 4.921 ft) | | | FT-FM2S FT-FM2S4 | |
| | FTP-N500 (0.5 m 1.640 ft) | FT-T80 | | FD-T40 | |
| | FTP-N1000 (1 m 3.281 ft) | FT-NFM2 | | | |
| | FTP-N1500 (1.5 m 4.921 ft) | FT-NFM2S FT-NFM2S4 | | | |
| Protective tube (For reflective type fiber) | FDP-500 (0.5 m 1.640 ft) | For M6 thread | Applicable fibers | FD-B8 | The protective tube, made of non-corrosive stainless steel, protects the inner fiber cable from any external forces. |
| | FDP-1000 (1 m 3.281 ft) | | | FD-FM2 | |
| | FDP-1500 (1.5 m 4.921 ft) | | | FD-FM2S FD-FM2S4 | |
| | FDP-N500 (0.5 m 1.640 ft) | FD-T80 | | | |
| | FDP-N1000 (1 m 3.281 ft) | FD-NFM2 | | | |
| | FDP-N1500 (1.5 m 4.921 ft) | FD-NFM2S FD-NFM2S4 | | | |
| Fiber bender | FB-1 | The fiber bender bends the sleeve part of the fiber head at the proper radius. | | | |
| Universal sensor mounting stand (Note 3) | MS-AJ1-F | Horizontal mounting type | Mounting stand assembly for fiber (For M3, M4 or M6 threaded) head fibers | | |
| | MS-AJ2-F | Vertical mounting type | | | |

Expansion lens
• FX-LE1

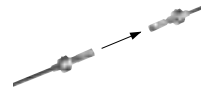

Super-expansion lens
• FX-LE2

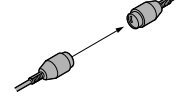

Side-view lens
• FX-SV1

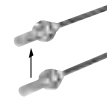

Pinpoint spot lens
• FX-MR1



Zoom lens
• FX-MR2

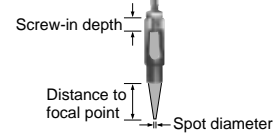

Finest spot lens
• FX-MR3



Digital panel controller

• CA2 series



• CA series



Protective tube

- FTP-□
- FDP-□



Fiber bender

- FB-1

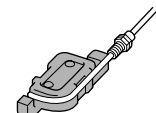

Universal sensor mounting stand

Using the arm which enables adjustment in the horizontal direction, sensing can also be done from above an assembly line.

- MS-AJ1-F

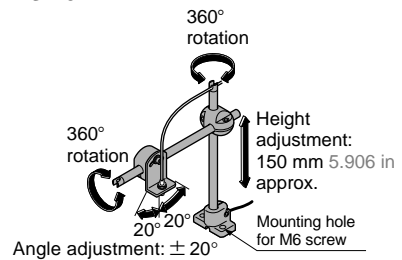

- MS-AJ2-F

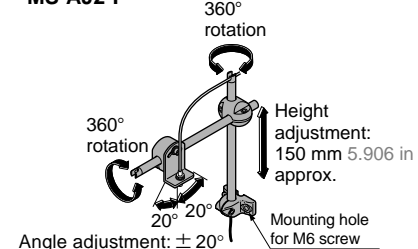

Notes: 1) The sensing range is defined as the range until the saturation indicator lights up.

2) For further details, refer to p.864~ for the ultra-compact digital panel controller CA2 series, and to p.854~ for the digital panel controller CA series.

3) Refer to P.332~ for the universal sensor mounting stand.

SPECIFICATIONS

Fibers

| Item \ Type | Type |
|--------------------------|---|
| | Standard, small fiber head, small diameter, sharp bend, long sensing range with lens, wide beam, array, high precision |
| Allowable bending radius | R25 mm R0.984 in or more [Sharp bend: R1 mm R0.039 in or more (FD-WG4 , FD-WSG4 : R2 mm R0.079 in or more)] |
| Ambient temperature | -40 to +70 °C -40 to +158 °F (Sharp bend: -40 to +60 °C -40 to +140 °F, FD-EG1 : -20 to +60 °C -4 to +140 °F) (No dew condensation or icing allowed), Storage: -40 to +70 °C -40 to +158 °F (Sharp bend: -40 to +60 °C -40 to +140 °F, FD-EG1 : -20 to +60 °C -4 to +140 °F) |
| Ambient humidity | 35 to 85 % RH, Storage: 35 to 85 % RH |
| Material | Fiber core: Acrylic Sheath: Polyethylene Fiber head: Brass (Nickel-plated) (Threaded part of standard, threaded part of small diameter, threaded type of sharp bend, high precision, array) Stainless steel (SUS) (FT-SFM2 , small fiber head, FT-SNFM2 , FD-SNFM2 , non-threaded type of sharp bend, FT-SFM2L , sleeve part of sleeve-attached fiber) Polycarbonate (FT-A8 , Lens of FT-WS8L), Polyolefin (Lens of FT-A8) |
| Accessories | All fibers: 1 fiber attachment set Free-cut type fibers: FX-CT2 1pc. (Fiber cutter) Threaded head fibers: nuts 2 pcs. (thru-beam type: 4 pcs.) and toothed lock washer 1 pc. (thru-beam type: 2 pcs.) FT-A8 : 0.5 × 12 mm 0.020 × 0.472 in seal type slit mask 2 pcs. and 1 × 12 mm 0.039 × 0.472 in seal type slit mask 2 pcs. |

Amplifier

| Item \ Model No. | Model No. | |
|----------------------------------|--|--|
| | FX-11A | |
| Supply voltage | 12 to 24 V DC ± 10 % Ripple P-P 10 % or less | |
| Current consumption | 35 mA or less | |
| Analog output | Analog voltage • Output voltage: 1 to 5 V (proportional to incident light intensity) • Output current: 5 mA or less • Output impedance: 47 Ω • Load resistance: 2 kΩ or more • Temperature characteristics: 0.3 % F.S./°C or less | |
| Response time | Switchable either 1 ms or less, or 10 ms or less | |
| Incident beam indicator | Red LED (brightens up in proportion to analog output voltage) | |
| Saturation indicator | Green LED (lights up when the analog output voltage reaches 5 V) | |
| Sensitivity adjuster | 8-turn potentiometer with indicator | |
| Interference prevention function | Incorporated | |
| Environmental resistance | Ambient temperature | -10 to +55 °C +14 to +131 °F (No dew condensation or icing allowed), Storage: -20 to +70 °C -4 to +158 °F |
| | Ambient humidity | 35 to 85 % RH, Storage: 35 to 85 % RH |
| | Ambient illuminance | Sunlight: 1,000 lx at the light-receiving face, Incandescent light: 1,000 lx at the light-receiving face |
| | Noise immunity | Power line: 240 Vp, 10 ms cycle, and 0.5 μs pulse width; Radiation: 300 Vp, 10 ms cycle, and 0.5 μs pulse width (with noise simulator) |
| | Voltage withstandability | 1,000 V AC for one min. between all supply terminals connected together and enclosure (Note 1) |
| | Insulation resistance | 20 MΩ, or more, with 250 V DC megger between all supply terminals connected together and enclosure (Note 1) |
| | Vibration resistance | 10 to 150 Hz frequency, 0.75 mm, 0.030 in amplitude in X, Y and Z directions for two hours each |
| Shock resistance | 100 m/s ² acceleration (10 G approx.) in X, Y and Z directions for five times each | |
| Emitting element | Red LED (modulated) | |
| Material | Enclosure: Heat-resistant ABS, Cover: Polycarbonate, Fiber lock lever: PES | |
| Cable | 0.2 mm ² 4-core cabtyre cable, 2 m 6.562 ft long | |
| Cable extension | Extension up to total 100 m 328.084 ft is possible with 0.3 mm ² , or more, cable. (Note 2) | |
| Weight | 60 g approx. | |
| Accessories | MS-DIN-2 (Amplifier mounting bracket): 1 pc., Adjusting screwdriver: 1 pc. | |

Notes: 1) The voltage withstandability and the insulation resistance values given in the above table are for the amplifier only.
 2) Take care that the output voltage drops when the cable is extended.

Fiber Selection

FX-301

 Digital Setting
 FX-302

FX-303

 Bank Selection Unit
 FX-CH

 Manually Set
 FX-311

 Analog Output
 FX-11A

 Color Detection
 FZ-10

FX-11A

I/O CIRCUIT AND WIRING DIAGRAMS

I/O circuit diagram

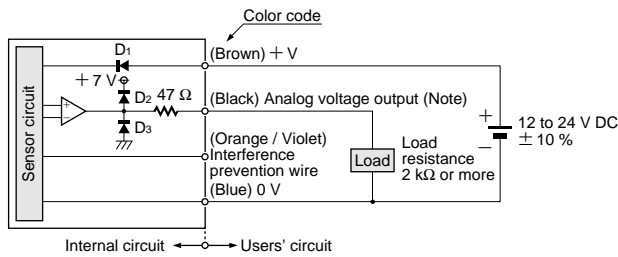

Wiring diagram

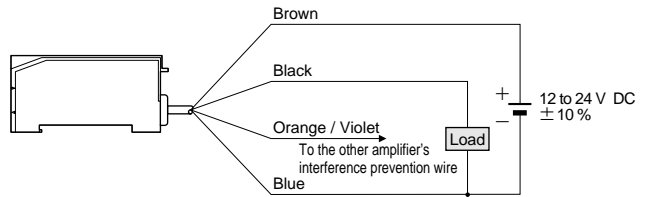

Note: The analog voltage output is not incorporated with a short-circuit protection circuit. Do not connect it directly to a power supply or a capacitive load.

Symbols ... D1: Reverse supply polarity protection diode
D2, D3: Surge absorption diode

SENSING CHARACTERISTICS (TYPICAL)

Correlation between setting distance and output voltage

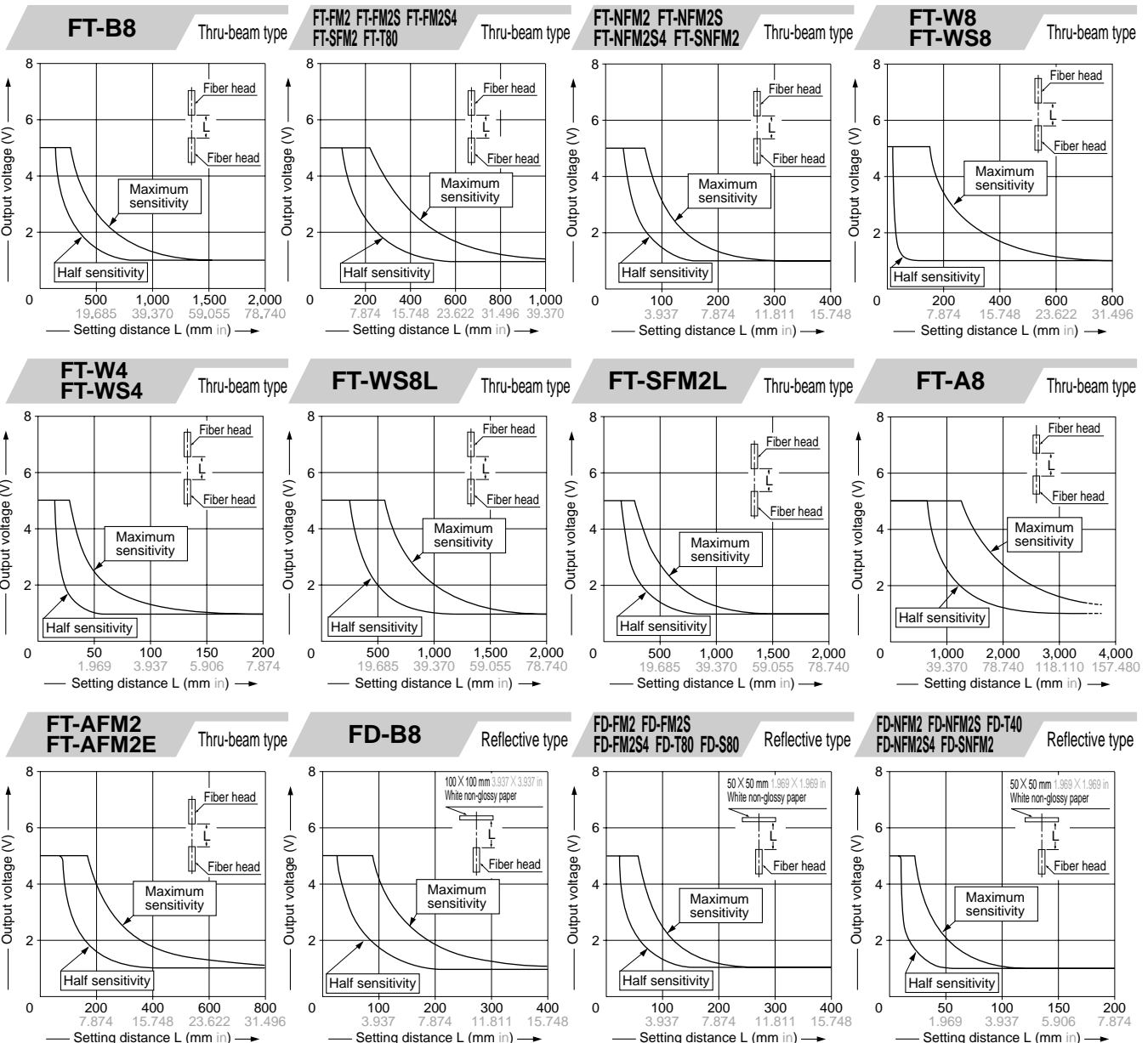

SENSING CHARACTERISTICS (TYPICAL)

Correlation between setting distance and output voltage

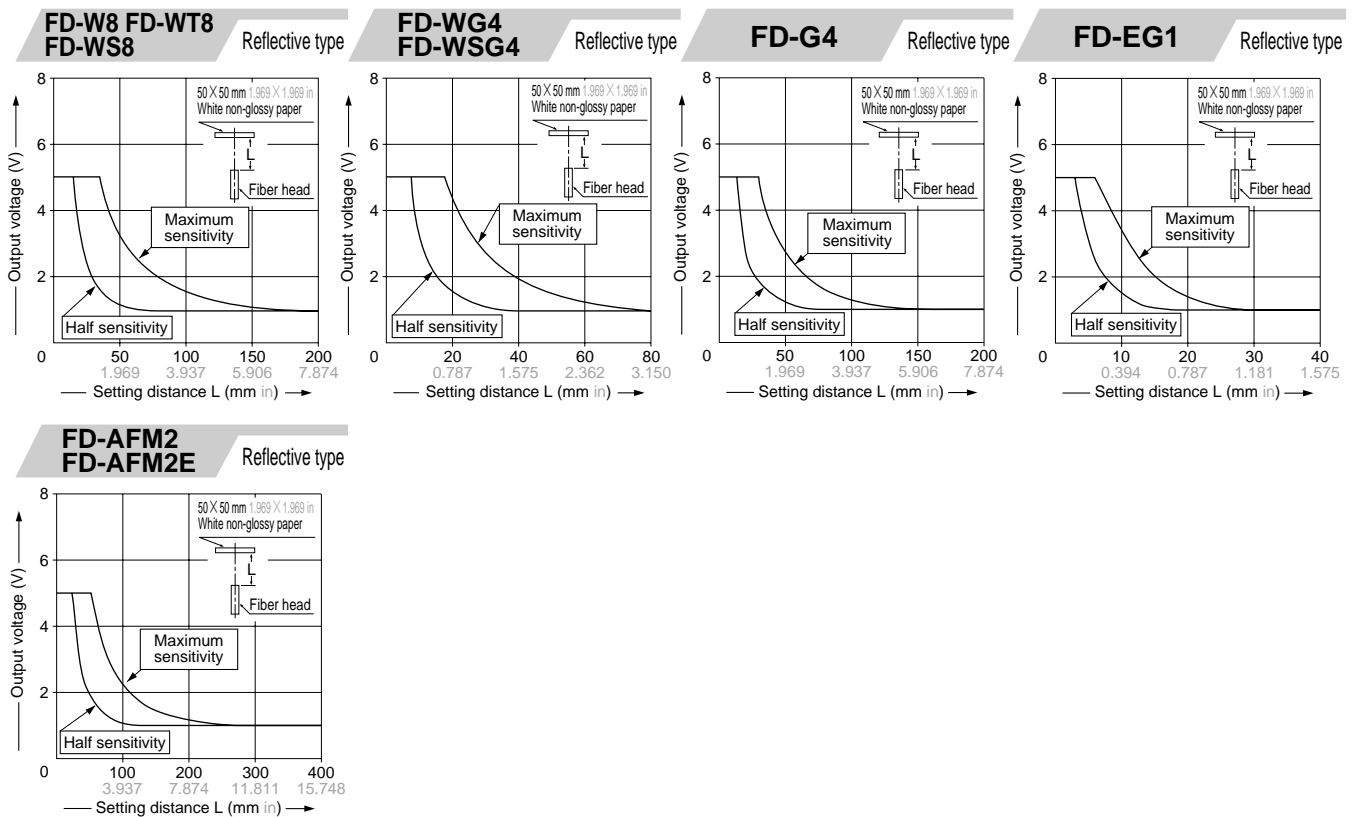

Correlation between setting distance and output voltage when using seal type slit masks

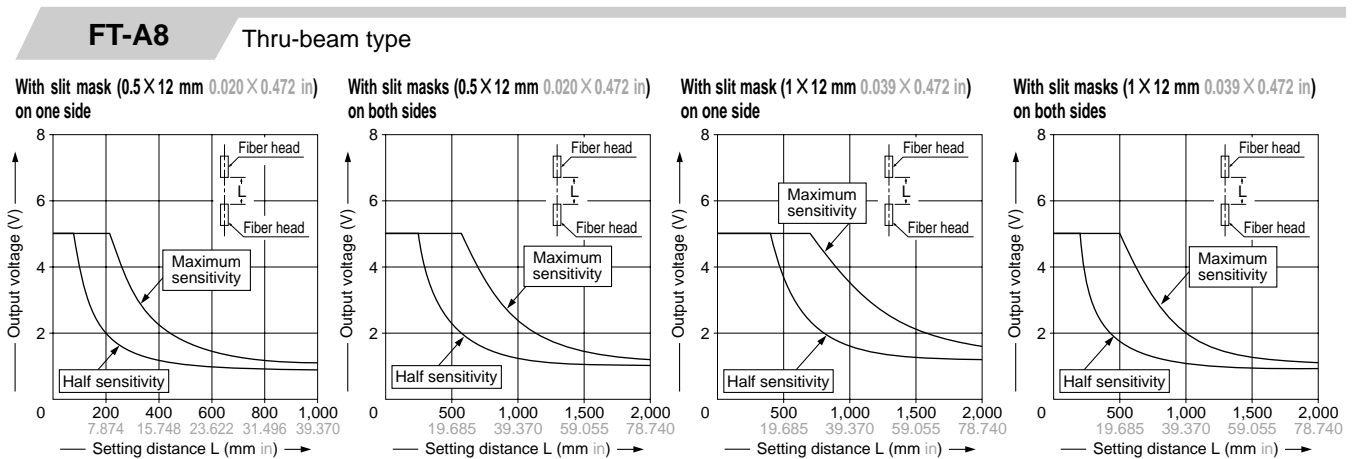

PRECAUTIONS FOR PROPER USE

Refer to p.1135~ for general precautions and p.94~ for fiber precautions.

Amplifier



This product is not a safety sensor. Its use is not intended or designed to protect life and prevent body injury or property damage from dangerous parts of machinery. It is a normal object detection sensor.

Mounting

How to mount the amplifier

- Fit the rear part of the amplifier on the attached amplifier mounting bracket (**MS-DIN-2**) or a 35 mm 1.378 in width DIN rail.
- Press down the front part of the amplifier on the amplifier mounting bracket (**MS-DIN-2**) or DIN rail to fit it.

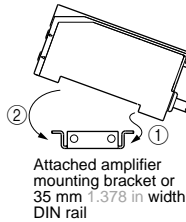

How to remove the amplifier

- Push the amplifier forward.
- Lift up the front part of the amplifier to remove it.

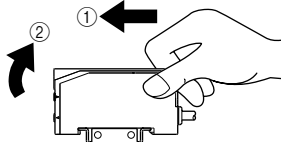

How to connect the fiber cables

- Unlock the fiber lock lever.
- Insert the fiber cables slowly into the inlets until they stop. (Note 1)
- Lock the fiber lock lever in the original position.

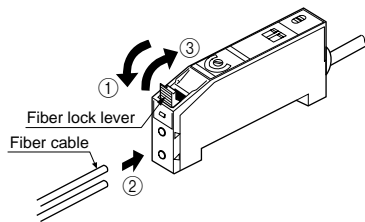

Notes: 1) In case the fiber cables are not inserted to a position where they stop, the sensing range reduces.
2) With the coaxial reflective type fiber, such as **FD-G4** or **FD-FM2**, insert the center fiber cable (single-core) into the beam-emitting inlet and the outer fiber cable (multi-core) into the beam-receiving inlet. If they are inserted in reverse, the sensing accuracy will deteriorate.

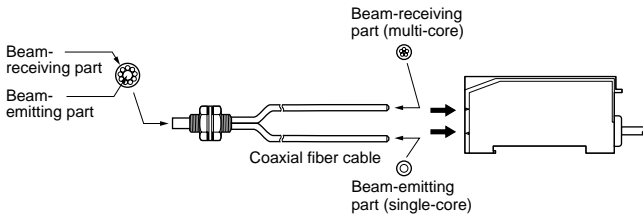

Interference prevention function

- Two sets of fibers can be mounted close together because an interference prevention function has been incorporated in **FX-11A**. The wiring and the setting of the interference prevention selection switch should be done as follows.

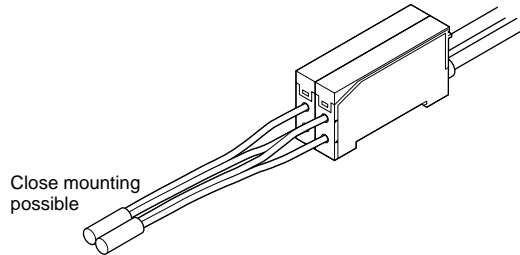

① Wiring

- Connect together the interference prevention wires and the 0 V wires of the two **FX-11A** amplifiers, respectively.

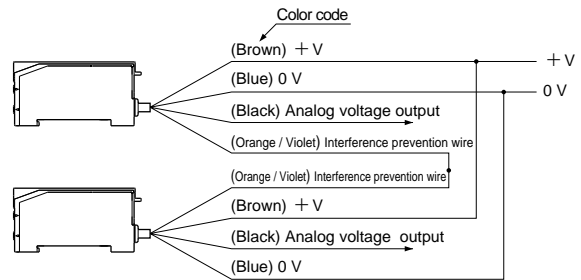

② Interference prevention selection switch

- Set the interference prevention selection switch to 'MAIN' for one amplifier and to 'SUB' for the other amplifier.
- ※ In case interference function is not used**
- Make sure to set the interference prevention selection switch to 'MAIN'. If it is set to 'SUB', the sensor will not work.
- Insulate the interference prevention wire.

PRECAUTIONS FOR PROPER USE

Refer to [p.1135](#)~ for general precautions and [p.94](#)~ for fiber precautions.

Amplifier

Response time selection

- The response time of **FX-11A** can be selected either '1 ms' or '10 ms'. If your detecting application does not need a quick response, '10 ms' is recommended as it makes the detection secure against inductive noise and ambient light. If you choose '1 ms', pay attention to electromagnetic noise and ambient light.
- The response time of **FX-11A** is the time required for the output voltage to rise from 1 V (dark state voltage) to [90 % of {light state voltage - 1 V (dark state voltage)} + 1 V (dark state voltage)] or the time required for the output voltage to fall from the light state voltage to [10 % of {light state voltage - 1 V (dark state voltage)} + 1 V (dark state voltage)]. The response time of **FX-11A** is constant regardless of the amplitude of the output voltage.

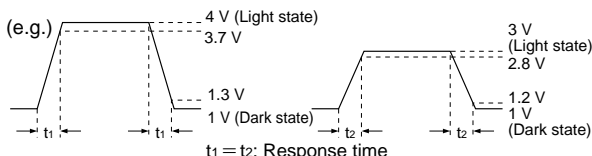

Part description

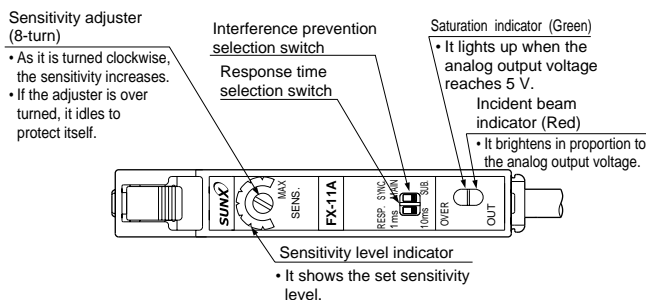

Sensitivity adjustment

| Step | Operation | Sensitivity adjuster |
|------|--|----------------------|
| ① | Turn the sensitivity adjuster fully counterclockwise (minimum sensitivity). | |
| ② | Adjust the relative positions of the fiber heads or the fiber head and the object so as to receive as much incident beam as possible. Thru-beam type Perfect beam-alignment Reflective type Maximum reflected beam | |
| ③ | Turn the sensitivity adjuster clockwise until the saturation indicator lights up. Once it lights up, turn the sensitivity adjuster counterclockwise until the saturation indicator lights off. This is the most sensitive point before saturation. | |

Others

- Do not use during the initial transient time (50 ms) after the power supply is switched on.
- The analog output is not incorporated with a short-circuit protection circuit. Do not connect it directly to a power supply or a capacitive load.

DIMENSIONS (Unit: mm in)

The CAD data in the dimensions can be downloaded from the SUNX website: <http://www.sunx.co.jp/>
Refer to [p.103](#)~ for dimensions other than those given in the figures below.

FX-11A Amplifier

Assembly dimensions with attached amplifier mounting bracket

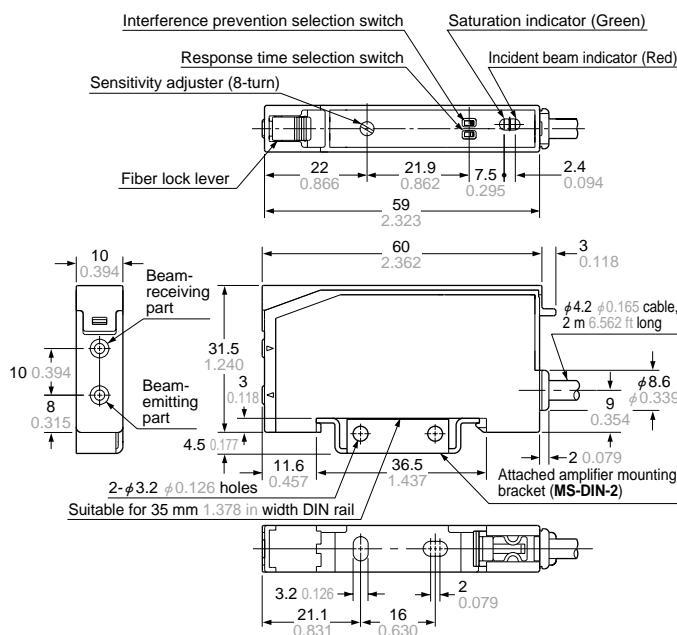

Note: The top view is shown without the cover.

MS-DIN-2 Amplifier mounting bracket (Accessory for FX-11A)

